

UL Design No. X671

February 03, 2006

Ratings - 1-1/2 and 2 Hr (See Item 2)

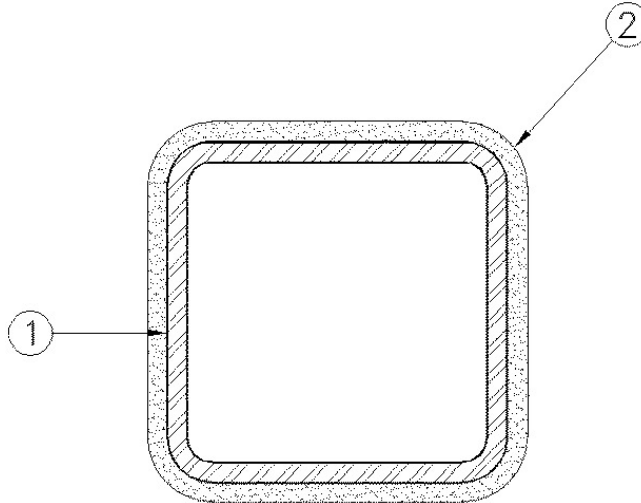

1. **Steel Column** — Square steel tube columns with the minimum sizes shown in the table below. Columns shall be free of dirt, loose scale and oil.

2. **Mastic Coating*** — Coating applied in accordance with manufacturers instructions to the minimum dry film thickness shown below:

			Required Min
Rating, hr	Column Size	Column, A/P	Thickness, In.
1-1/2	ST 10 x 10 x 5/16 in.	0.30	0.188
2	ST 10 x 10 x 5/16 in	0.30	0.257

A/D FIRE PROTECTION SYSTEMS INC — Type "A/D FIREFILM III" investigated for Interior Conditioned Space Purpose and Interior General Purpose.

3. **Top Coat** — (Not shown) — Finishing topcoat, Type "A/D COLORCOAT" silicone alkyd paint applied at an approximate 0.002 in. dry film thickness.

*Bearing the UL Classification Mark