

ULC Design No. Z628

November 25, 2005

Ratings – 1-1/2 and 2 h (See Item 2)

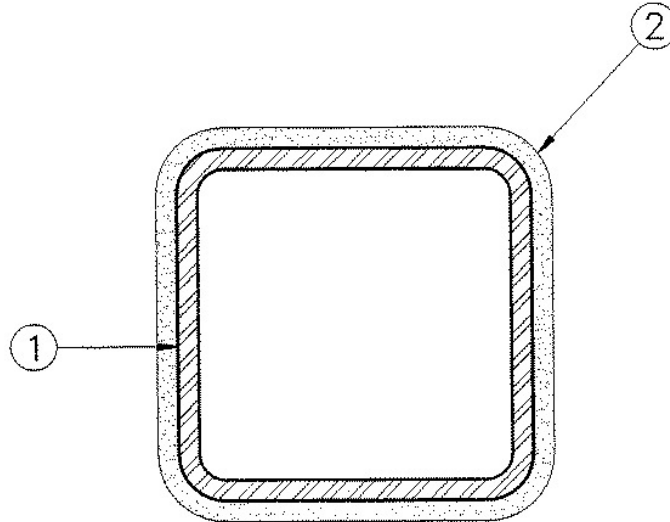

1. **Steel Column** — Square, hollow structural section (HSS) with M/D as specified in Item 2. All columns should be free of dirt, loose scale and oily deposits.

2. **Thin-Film Intumescent Coatings** — CAVCC (Guide No. 40 U18.12.9). Intumescent coating designated "A/D FIREFILM III", applied in accordance with manufacturer's instructions to the minimum dry film thicknesses shown below. Column surfaces should be primed as per manufacturer's instructions.

Ratings, h	Min Column Size, mm	Min M/D	Required Min Dry Film Thickness, mm
1-1/2	HSS 254 x 254 x 8	59	4.78
2	HSS 254 x 254 x 8	59	6.54

M = Mass of column section, kg/m.

D = Heated perimeter of column section, m.

A/D FIRE PROTECTION SYSTEMS INC

3. **Finish Coating** – (not shown) – Silicone alkyd paint designated "A/D COLORCOAT".