

ULC Design No. F818

April 01, 2003

Restrained Assembly Rating - 1 h

Unrestrained Assembly Rating - 1 h

Unrestrained Beam Rating - (See Table Below)

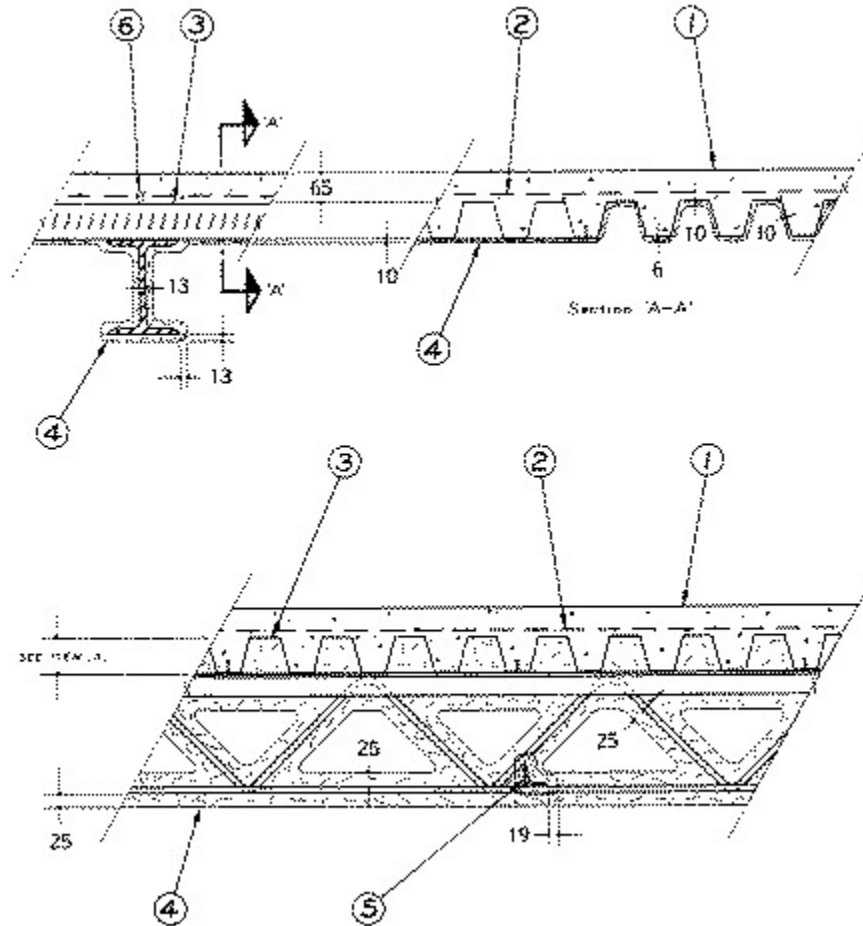

1. **Normal-Density or Low-Density Concrete** - Normal-density concrete, carbonate or siliceous aggregate, $242\pm 50 \text{ kg/m}^3$, 21 MPa nom compressive strength. Low-density concrete, expanded shale, clay, or slate aggregate by rotary kiln method, $184\pm 50 \text{ kg/m}^3$, 21 MPa nom compressive strength; or expanded blast furnace slag aggregate, $1955\pm 50 \text{ kg/m}^3$ density, 21 MPa nom. compressive strength.
2. **Wire Fabric** - 152x152 P18.7/P18.7 steel wire.
3. **Steel Floor Units** - (Guide No. 40 U18.19). Composite or noncomposite floor units, all 0.76 mm thick fluted sections or alternating one 915 mm or 610 mm wide 0.76 mm fluted section to a maximum of one 610 mm wide 0.91/0.91 mm cellular section. Units welded to supports with 20 mm diam welds spaced at every other trough. Adjacent units crimped along joints at 450 mm OC. See individual manufacturer's listing for profiles that may be used in this design.

**LES ACIERS CANAM, DIV OF LE GROUPE
CANAM MANAC INC
FLYNN CANADA LTD
VICWEST CORP**

ULC Design F818 continued...

4(a). **Spray-Applied Fire-Resistive Material** - (Guide No. 40 U18.6). "A/D Type FP" fibre for application with or without adhesive to steel surfaces in thicknesses indicated above. Fibre to have a min. average dry density of 165 kg/m^3 with a min individual value of 145 kg/m^3 . For method of density determination, refer to General Information Section under heading "Fire Resistance Ratings". Steel surfaces must be clean and free of dirt, loose scale and oily deposits.

OR

· 4(b). **Spray-Applied Fire-Resistive Material** - (Guide No. 40 U18.6). "A/D Type 5" spray-applied fire-resistive material for application with or without adhesive to steel surfaces in thicknesses indicated above (fluted units only). Mixture to have a min average dry density of 272 kg/m^3 with a min individual value of 248 kg/m^3 . For method of density determination, refer to General Information Section under heading "Fire Resistance Ratings". Steel surfaces must be clean and free of dirt, loose scale and oily deposits.

A/D FIRE PROTECTION SYSTEMS INC

5. **Bridging** - Designed in accordance with the relevant provisions of Part 4 of the National Building Code of Canada, protected with 19 mm min "A/D Type FP" spray-applied fire-resistive material (Item 4a) with a min. average density of 165 kg/m^3 , or "A/D Type 5" spray-applied fire-resistive material (Item 4b) with a min. average density of 272 kg/m^3 .
6. **Shear Connectors** - (optional) - Studs, 13 mm dia. by 100 mm long, headed type. Welded to top flange of beam through the deck.

Unrestrained Beam Rating, h	Description of Beam
1	W200x31, min size
1	250 mm deep, open web steel joist, 9 kg/m min size,
	designed in accordance with the relevant provisions of
	Part 4 of the National Building Code of Canada.