

DESIGN NO. AD/PHV 120-02

****FIRE RATED NONFLAMMABLE ACOUSTIC/SMOKE SEAL FIRESTOP SEALANT, Horizontal or Vertical (Floor/Ceiling or Wall); RATINGS - See Below
Test Furnace Internal Positive Pressure Differential - 2.5 Pa (0.01" of water) Minimum**

	Fire "F"	Hose "FH"	Temperature "FTH"
ASTM-E814	2 hours	2 hours	2 hours
CAN/ULC-S115	2 hours	2 hours	2 hours

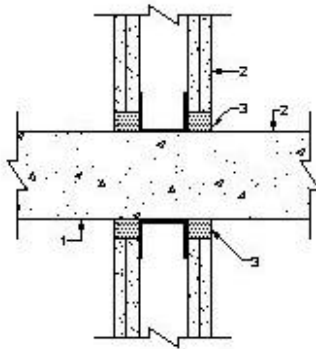

1. **Penetrating Item** - Not Applicable (Not Shown).
2. **Floor/Ceiling or Fire Separations** - 1, 2 hour rated ASTM-E119 or CAN/ULC-S101 concrete floor assembly and/or metal or wood framed fire rated gypsum wallboard (GWB) wall assemblies.
3. **Firestop System** - A/D FIREBARRIER Silicone* or Seal NS* at a minimum bead diameter of 3/8" (10mm) caulked into the corner between the ends of the GWB around the entire perimeter of the fire rated wall assembly.
4. **Firestop System** - Filler material not required (Not Shown).

*Components bearing the Warnock Hersey Certification Mark.

**The acoustic/smoke seal claims have not been verified by Intertek Testing Services.