

**Through-penetration Firestop Systems**  
**UL System No. C-AJ-1558**  
**F Rating - 3 Hr**  
**T Rating - 0 Hr**

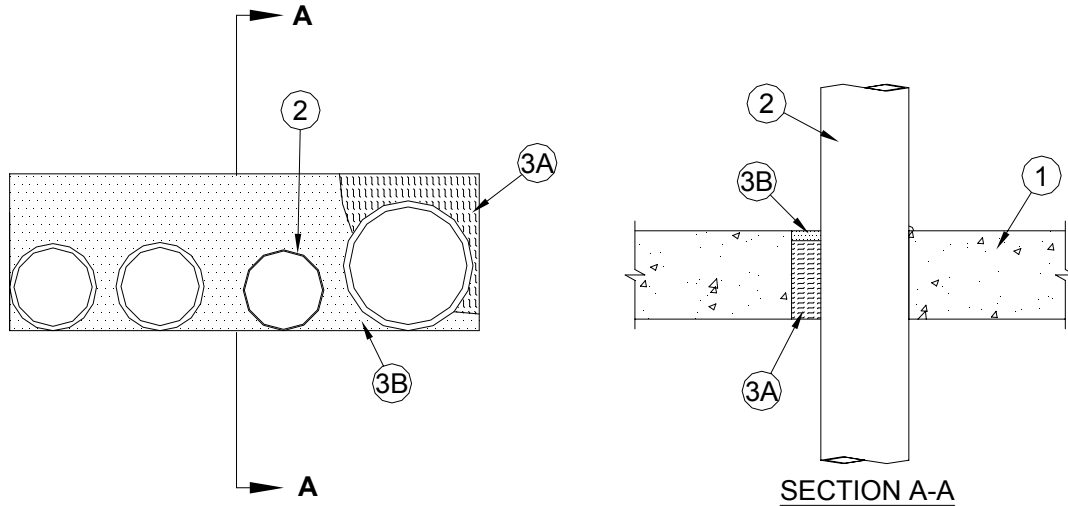

1. **Floor or Wall Assembly** - Min. 4-1/2 in. (114 mm) thick reinforced lightweight or normal weight (100-150 pcf (1600-2400 kg/m<sup>3</sup>)) concrete floor. Wall may also be constructed of any UL Classified **Concrete Blocks\***. Max. area of opening is 192 sq in. with a max. dimension of 24 in. (610 mm).

See **Concrete Blocks** (CAZT) category in the Fire Resistance Directory for names of manufacturers.

2. **Through Penetrants** - One or more pipes, conduits or tubing to be installed within the opening. The space between the pipes, conduits or tubes shall be min. 1 in. (25 mm) to max. 2 in. (51 mm). The annular space between the pipes, conduits or tubing and the periphery of the opening shall be min. 0 in. (point contact) to max. 3-7/8 in. (98 mm). Pipes, conduits or tubing to be rigidly supported on both sides of floor or wall assembly. The following types and sizes of metallic pipes, conduits or tubing may be used:
  - A. **Steel Pipe** - Nom. 8 in. (203 mm) dia. (or smaller) Schedule 5 (or heavier) steel pipe.
  - B. **Iron Pipe** - Nom. 8 in. (203 mm) dia. (or smaller) cast or ductile iron pipe.
  - C. **Conduit** - Nom. 4 in. (102 mm) dia. (or smaller) steel electrical metallic tubing (EMT) or nom 6 in. (152 mm) dia. (or smaller) rigid conduit.
  - D. **Copper Pipe** - Nom. 4 in. (102 mm) dia. (or smaller) Regular (or heavier) copper pipe.
  - E. **Copper Tube** - Nom. 4 in. (102 mm) dia. (or smaller) Type L (or heavier) copper tube.

3. **Firestop System** - The firestop system shall consist of the following:
  - A. **Forming Material** - Min. 4 in. (102 mm) thickness of 4 pcf (64 kg/m<sup>3</sup>) mineral wool batt insulation tightly packed into the annular space, recessed 1/2 in. (13 mm) from top surface of floor or both surfaces of wall to accommodate fill material (Item 3B). The insulation is formed from one piece, cut to the shape of the through opening, and tightly packed with a 50 percent compression in the width direction. Additional pieces of insulation tightly packed in to fill any remaining voids. Packing material recessed from top surface of floor or both surfaces of wall unit as required to accommodate fill material (Item 3B).
  - B. **Fill, Void or Cavity Material\* - Caulk** -- Min. 1/2 in. (13 mm) thickness of fill material applied within annulus, flush with top surface of floor assembly or both surfaces of wall assembly. At point contact locations, min. 1/4 in. (6 mm) dia. bead of fill material applied at metallic pipe/concrete interface on top surface of floor or on both surfaces of wall.

**A/D FIRE PROTECTION SYSTEMS INC - A/D FIREBARRIER Intumescent Sealant**

\*Bearing the UL Classification Mark