

Through-penetration Firestop Systems
UL System No. C-AJ-3275
F Rating - 4 Hr
T Ratings - 2-1/2 and 4 Hr (See Item 2)
L Rating at Ambient - 4.0 CFM/Sq Ft

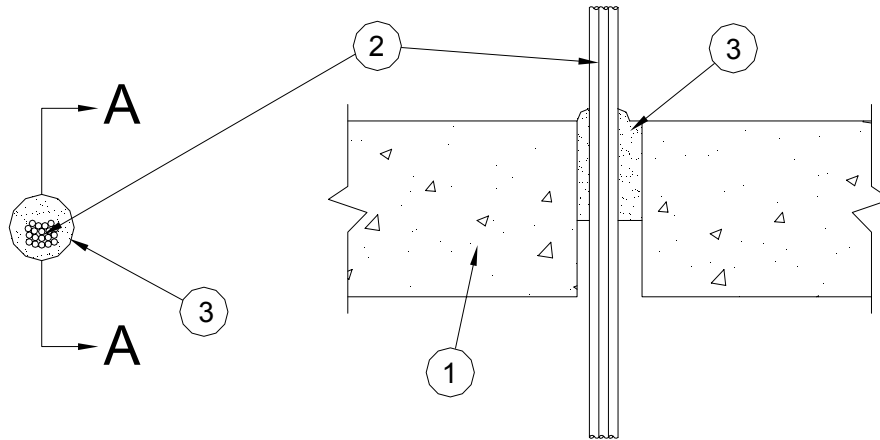

SECTION A-A

1. **Floor or Wall Assembly** - Min. 5-1/2 in. (140 mm) thick for floors, or min. 6 in. (152 mm) thick for walls, reinforced lightweight or normal weight (100-150 pcf (1600-2400 kg/m³)) concrete. Wall may also be constructed of any UL Classified **Concrete Blocks***. Max. dia. of opening is 2 in. (51 mm).

See **Concrete Blocks** (CAZT) category in the Fire Resistance Directory for names of manufacturers.

2. **Cables** - Aggregate cross-sectional area of cables in opening to be max. 25 percent of the cross-sectional area of the opening. Tight bundle of cables to be installed in the opening. The annular space within the firestop system shall be a min. of 3/8 in. (10 mm) to a max. of 5/8 in. (16 mm). Cables to be rigidly supported on both sides of the floor or wall assembly. Any combination of the following types and sizes of cables may be used:
 - A. Max. 4 pair No. 24 AWG (or smaller) copper conductor cable with polyvinyl chloride (PVC) jacketing and insulation. **When 4 pair No. 24 AWG cable is used, T Rating is 4 Hr.**
 - B. Max. 3/C with ground No. 8 AWG (or smaller) copper conductor NM cable (Romex) with PVC insulation and jacket. **When Romex cable is used, T Rating is 2-1/2 Hr.**

3. **Fill, Void or Cavity Material* - Putty** - Min. 3 in. (76 mm) thickness of fill material applied within the annulus, flush with top surface of floor or both surfaces of wall assembly. Fill material to be forced into interstices of cable group to max extent possible. Min. 3/8 in. (10 mm) bead of fill material to be applied around perimeter of cable bundle.

A/D FIRE PROTECTION SYSTEMS INC - A/D FIREBARRIER Putty II

*Bearing the UL Classification Mark