

**Through-penetration Firestop Systems**  
**System No. C-AJ-5305**  
**F Rating - 2 and 3 Hr (See Item 4B)**  
**T Rating - 1, 1-1/4 and 1-1/2 Hr (See Item 4B)**

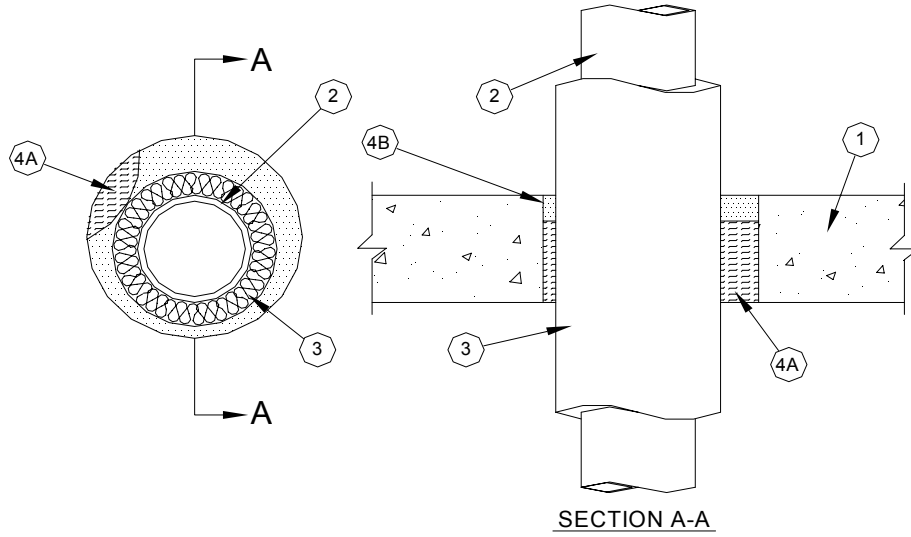

FIRESTOP CONFIGURATION A

Configuration B

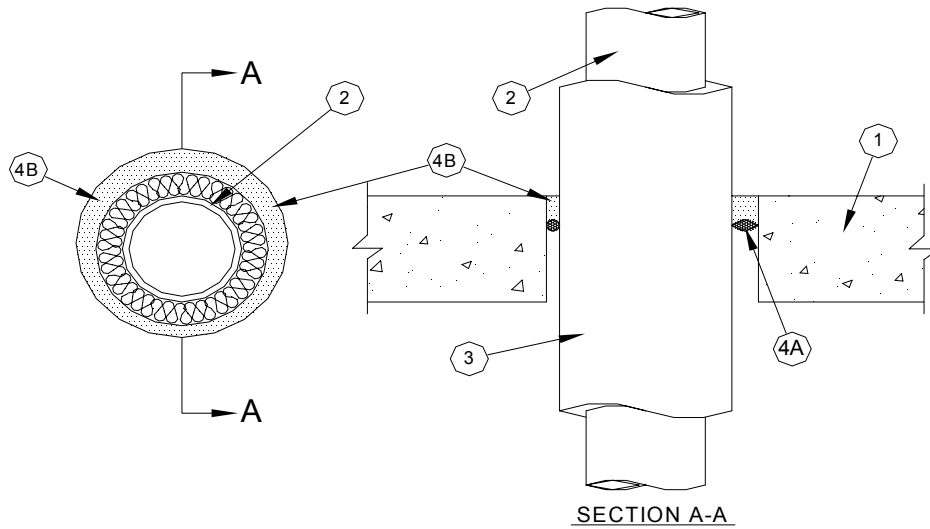

**UL System C-AJ-5305 continued...**

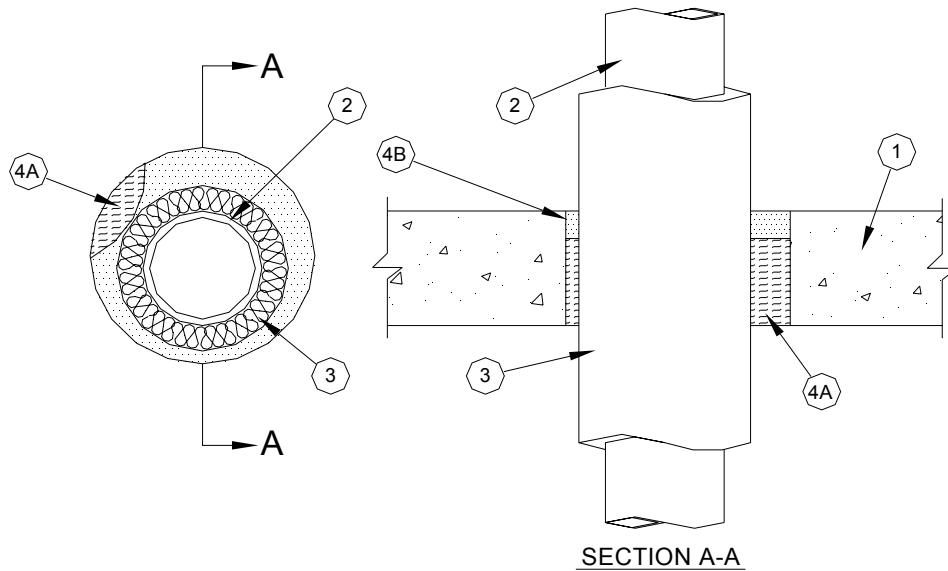

- 1. Floor or Wall Assembly** - Min. 4-1/2 in. (114 mm) thick reinforced lightweight or normal weight (100-150 pcf (1600-2400 kg/m<sup>3</sup>)) concrete floor or min. 5 in. (127 mm) thick reinforced lightweight or normal weight concrete wall. Wall may also be constructed of any UL Classified **Concrete Blocks\***. Floor may also be constructed of any min. 6 in. (152 mm) thick UL Classified hollow-core **Precast Concrete Units\***. If the firestop system is installed within a hollow-core precast concrete unit, max. dia. of opening shall be 7 in. (178 mm) Otherwise, see Table under Item 4B for max. dia. of opening.

See **Concrete Blocks** (CAZT) and **Precast Concrete Units** (CFTV) categories in the Fire Resistance Directory for names of manufacturers.

- 2. Through Penetrants** - One metallic pipe or tubing to be installed either concentrically or eccentrically within the firestop system. Pipe or tubing to be rigidly supported on both sides of floor or wall assembly. See Table under Item 4B for max sizes of pipes that may be used. The following types of metallic pipes or tubing may be used:
  - A. Steel Pipe** - Schedule 10 (or heavier) steel pipe.
  - B. Iron Pipe** - Cast or ductile iron pipe.
  - C. Copper Tubing** - Type L (or heavier) copper tubing.
  - D. Copper Pipe** - Regular (or heavier) copper pipe.

- 3. Pipe Covering\*** - Nom. 1, 2 or 3 in. (25, 51 or 76 mm) thick (see table under Item 4B) hollow cylindrical heavy density (min. 3.5 pcf (56 kg/m<sup>3</sup>)) glass fiber units jacketed on the outside with an all service jacket. Longitudinal joints sealed with metal fasteners or factory-applied self-sealing lap tape. Transverse joints secured with metal fasteners or with butt tape supplied with the product. See Table under Item 4B for annular space required within the firestop system.

See **Pipe and Equipment Covering - Materials** (BRGU) category in the Building Materials Directory for names of manufacturers. Any pipe covering material meeting the above specifications and bearing the UL Classification Marking with a Flame Spread Index of 25 or less and a Smoke Developed Index of 50 or less may be used.

**UL System C-AJ-5305 continued...**

**4. Firestop System** - The firestop system shall consist of the following:

- A. **Packing Material** - Min. 4 pcf (64 kg/m<sup>3</sup>) mineral wool batt insulation firmly packed into opening , to the min. thickness specified in the table under Item 4B, as a permanent form. Packing material to be recessed from top surface of floor or from both surfaces of wall and hollow-core precast concrete unit as required to accommodate the required thickness of fill material.
- B. **Fill, Void or Cavity Material\* - Caulk** - Fill material applied within the annulus, flush with top surface of floor or with both surfaces of wall and hollow-core precast concrete unit. Min. thickness of fill material specified in table below.

**A/D FIRE PROTECTION SYSTEMS INC - A/D FIREBARRIER Intumescent Sealant**

F Rating Hr	T Rating Hr	Max Pipe Dia., in. (mm)		Pipe Covering Thick, in. (mm)	Packing Material Thick, in. (mm)	Max Open Dia., in. (mm)	Fill Mtl Thick in. (mm)	Annular Space, in. (mm)
		Copper	Steel, Iron					
2	1	4 (102)	6 (152)	1 (25)	4 (102)	8-5/8 (219)	1/2 (13)	1/2 to 1- 3/8 (13 to 35)
3	1-1/2	4 (102)	6 (152)	2 (51)	3-1/2 (89)	10-5/8 (270)	1 (25)	1/2 to 1- 3/8 (13 to 35)
2	1-1/2	6 (152)	8 (152)	3 (76)	3-1/2 (89)	18-3/4 (476)	1 (25)	1-3/4 to 2 (44 to 51)

\*Bearing the UL Classification Mark