

Through-penetration Firestop Systems
UL System No. C-AJ-8183
F Rating - 2 Hr
T Rating - 0 Hr

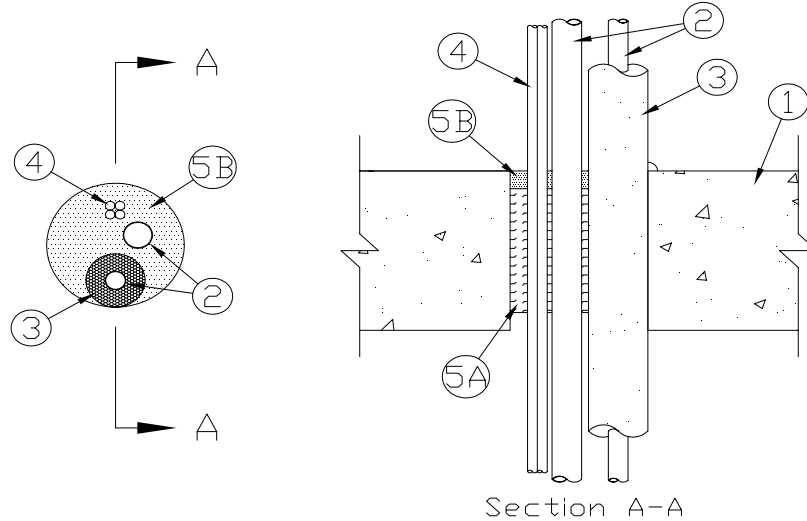

1. **Floor or Wall Assembly** - Min. 4-1/2 in. (114 mm) thick reinforced lightweight or normal weight (100-150 pcf (1600-2400 kg/m³)) concrete floor or min. 5-1/2 in. (140 mm) thick reinforced lightweight or normal weight concrete wall. Floor may also be constructed of any min. 6 in. (152 mm) thick UL Classified hollow-core **Precast Concrete Units***. Wall may also be constructed of any UL Classified **Concrete Blocks***. Max. dia. of opening is 3-1/2 in. (89 mm) .

See **Concrete Block (CAZT)** and **Precast Concrete Units (CFTV)** categories in the Fire Resistance Directory for names of manufacturers.

2. **Through-Penetrants** - A max. of two pipes, conduits or tubing to be installed within the opening. Of the two pipes, conduits or tubing, only one of the pipes, conduit or tubing shall have a nom. dia. greater than 1/2 in. (13 mm). The annular space between pipes, conduits or tubing and the periphery of the opening shall be min. 1/4 in. (6 mm) to max. 1-1/2 in. (38 mm). Pipes, conduits or tubing to be rigidly supported on both sides of floor or wall assembly. The following types and sizes of metallic pipes, conduits or tubing may be used:

- A. **Steel Pipe** - Nom. 3/4 in. (19 mm) dia. (or smaller) Schedule 10 (or heavier) steel pipe.
- B. **Iron Pipe** - Nom. 3/4 in. (19 mm) dia. (or smaller) cast or ductile iron pipe.
- C. **Conduit** - Nom. 3/4 in. (19 mm) dia. (or smaller) steel electrical metallic tubing or nom 3/4 in. dia. (or smaller) steel conduit.
- D. **Copper Tubing** - Nom. 3/4 in. (19 mm) dia. (or smaller) Type L (or heavier) copper tubing.
- E. **Copper Pipe** - Nom 3/4 in. (19 mm) dia. (or smaller) Regular (or heavier) copper pipe.

3. **Tube Insulation - Plastics+** - Nom. 1/2 in. (13 mm) thick acrylonitrile butadiene/polyvinyl chloride (AB/PVC) flexible foam furnished in the form of tubing. The tube insulation may be installed on a max of one pipe or tubing. The annular space between insulated penetrating item and periphery of opening shall be min. 1/2 in. (13 mm) to max. 1 in. (25 mm) . The annular space between pipes or tubing shall be a min. 0 in. (point contact) to a max 1/2 in. (13 mm).

See **Plastics+** (QMFZ2) category in the Recognized Component Directory for names of manufacturers. Any Recognized Component tube insulation material meeting the above specifications and having a UL 94 Flammability Classification of 94-5VA may be used.

UL System C-AJ-8183 continued...

4. **Cables** - Max. four, 4 pair No. 18 AWG (or smaller) thermostat cable with polyvinyl chloride (PVC) insulation and jacket materials. Cables to be spaced a min. 0 in. (point contact) to max. 1/2 in. (13 mm) from the other penetrants. The annular space between the cable and the periphery of the opening shall be a min. 1/2 in. (13 mm) to max. 1 in. (25 mm). Cables to be rigidly supported on both sides of wall assembly.
5. **Firestop System** - The firestop system shall consist of the following:
 - A. **Packing Material** - Min. 3-1/2 in. (89 mm) thickness of min 4 pcf (64 kg/m³) mineral wool batt insulation firmly packed into opening as a permanent form. Packing material to be forced into interstices of through penetrants to max. extent possible. Packing material to be recessed from top surface of concrete floor or from both surfaces of wall as required to accommodate the required thickness of fill material. When floor is constructed of hollow-core precast concrete unit, packing material to be recessed from both surfaces of floor to accommodate the required thickness of fill material.
 - B. **Fill, Void or Cavity Material* - Sealant** - Min. 1 in. (25 mm) thickness of fill material applied within the annulus, flush with top surface of concrete floor or with both surfaces of wall assembly. Fill material to be forced into interstices of through penetrants to max. extent possible. When floor is constructed of hollow-core precast concrete unit, fill material to be installed symmetrically on both sides of floor, flush with floor surfaces. When thickness of packing material (Item 5A) increased to 4-1/4 in. (108 mm), min fill material thickness is 1/4 in. (6 mm).

A/D FIRE PROTECTION SYSTEMS INC - A/D FIREBARRIER Intumescent Sealant

+Bearing the UL Recognized Component Mark

*Bearing the UL Classification Mark