

**UL System No. C-AJ-8184**  
**F Rating - 3 Hr**  
**T Rating - 0**

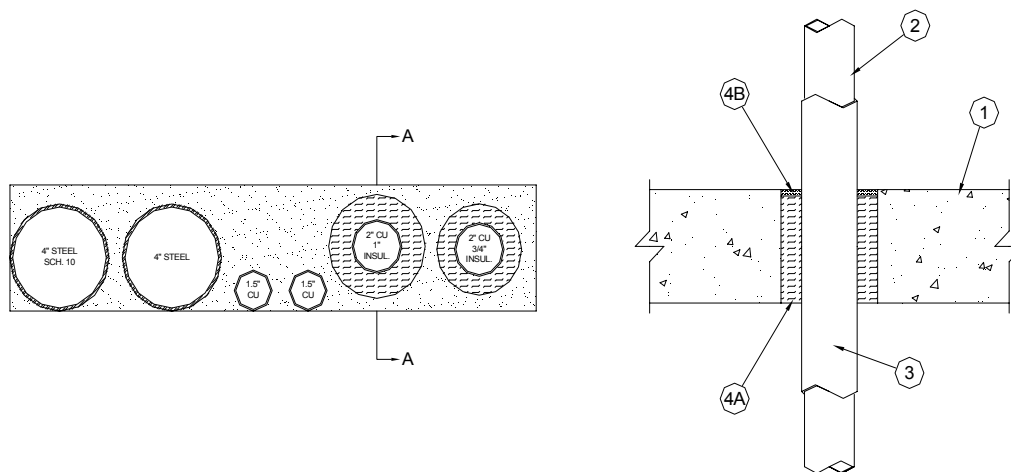

1. **Floor or Wall Assembly** - Min. 4-1/2 in. (114 mm) thick reinforced lightweight or normal weight (100-150 pcf (1600-2400 kg/m<sup>3</sup>)) concrete floor or min 5 in. (127 mm) thick reinforced lightweight or normal weight concrete wall. Wall may also be constructed of any UL Classified **Concrete Blocks\***. Max. area of opening is 112.5 sq in. (726 sq cm) with max dimension of 22.5 in. (572 mm).

See **Concrete Block** (CAZT) category in the Fire Resistance Directory for names of manufacturers.

2. **Through-Penetrants** - One or more pipes, conduits or tubing to be installed within the opening. The annular space between non-insulated pipes, conduits or tubing and the periphery of the opening shall be min. 0 in. (point contact) to max. 3-3/8 in. (86 mm). The annular space between insulated pipes, conduits or tubing and the periphery of the opening shall be min. 1/2 in. (13 mm) to max. 1 in. (25 mm). The annular space between the pipes, conduits or tubing shall be min. 1/2 in. (13 mm) to max. 5/8 in. (16 mm). Pipes, conduits or tubing to be rigidly supported on both sides of floor or wall assembly. The following types and sizes of metallic pipes, conduits or tubing may be used:

- A. **Steel Pipe** - Nom. 4 in. (102 mm) dia. (or smaller) Schedule 10 (or heavier) steel pipe. When pipe covering (Item 3) is used, pipe size is nom 2 in. (51 mm) dia. (or smaller).
- B. **Iron Pipe** - Nom. 4 in. (102 mm) dia. (or smaller) cast or ductile iron pipe. When pipe covering (Item 3) is used, pipe size is nom 2 in. (51 mm) dia. (or smaller).
- C. **Conduit** - Nom. 4 in. (102 mm) dia. (or smaller) steel electrical metallic tubing or nom. 4 in. (102 mm) dia. (or smaller) steel conduit.
- D. **Copper Tubing** - Nom. 2 in. (51 mm) dia. (or smaller) Type L (or heavier) copper tubing.
- E. **Copper Pipe** - Nom. 2 in. (51 mm) dia. (or smaller) Regular (or heavier) copper pipe.

**When through penetrant D or E is used without pipe covering (Item 3), the T Rating is 0 hr.**

3. **Pipe Coverings\*** - One of the following types of pipe coverings may be installed on one or more of through-penetrants A, B, D and E:

- A. **Pipe and Equipment Covering Materials\*** - Nom. 1 in. (25 mm) thick hollow cylindrical heavy density (min 3.5 pcf (56 kg/m<sup>3</sup>)) glass fiber units jacketed on the outside with an all service jacket. Longitudinal joints sealed with metal fasteners or factory-applied self-sealing lap tape. Transverse joints secured with metal fasteners or with butt tape supplied with the product.

## UL System C-AJ-8184 continued...

See **Pipe and Equipment Covering - Materials\*** (BRGU) category in the Building Materials Directory for names of manufacturers. Any pipe covering material meeting the above specifications and bearing the UL Classification Marking with a Flame Spread Index of 25 or less and a Smoke Developed Index of 50 or less may be used.

B. **Tube Insulation - Plastics+** - Nom. 3/4 in. (19 mm) thick acrylonitrile butadiene/polyvinyl chloride (AB/PVC) flexible foam furnished in the form of tubing.

See **Plastics+** (QMFZ2) category in the Plastics Recognized Component Directory for names of manufacturers. Any Recognized Component tube insulation material meeting the above specifications and having a UL 94 Flammability Classification of 94-5VA may be used.

4. **Firestop System** - The firestop system shall consist of the following:

- A. **Packing Material** - Min. 4 in. (102 mm) thickness of min. 4 pcf (64 kg/m<sup>3</sup>) mineral wool batt insulation firmly packed into opening as a permanent form. Packing material to be recessed from top surface of floor or from both surfaces of wall as required to accommodate the required thickness of fill material.
- B. **Fill, Void or Cavity Material\* - Sealant** - Min. 1/2 in. (13 mm) thickness of fill material applied within the annulus, flush with top surface of floor or with both surfaces of wall assembly. At the point contact location between through penetrant and concrete, a min. 1/4 in. (6 mm) dia. of fill material shall be applied at the concrete/through penetrant interface on top surface of floor or both surfaces of wall assembly.

**A/D FIRE PROTECTION SYSTEMS INC - A/D FIREBARRIER Intumescent Sealant**

+Bearing the UL Recognized Component Mark

\*Bearing the UL Classification Mark