

Through-penetration Firestop Systems
UL System No. W-L-1417
F Rating - 2 Hr
T Rating - 0 Hr

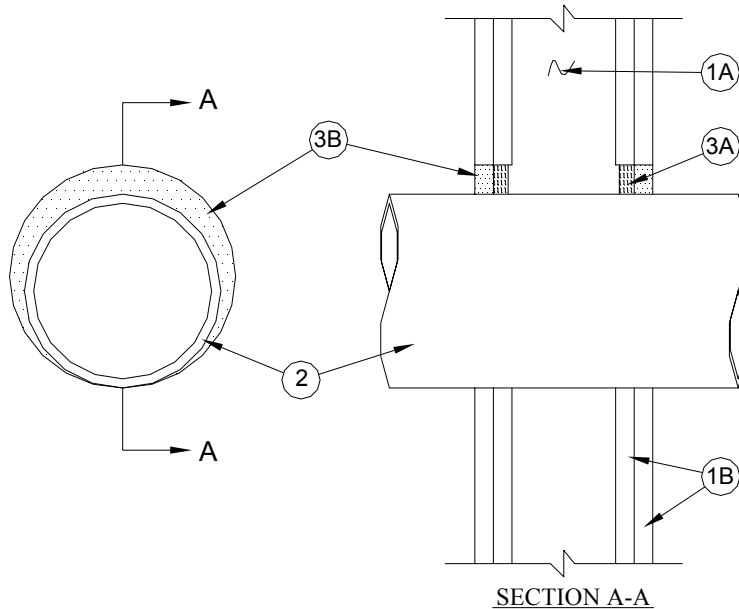

1. **Wall Assembly** - The fire-rated gypsum bord/stud wall assembly shall be constructed of the materials and in the manner specified in the individual U300 or U400 Series Wall and Partition Designs in the UL Fire Resistance Directory and shall include the following construction features:
 - A. **Studs** - Wall framing may consist of either wood studs or steel channel studs. Wood studs to consist of nom. 2 by 4 in. (51 by 102 mm) lumber spaced 16 in. (406 mm) OC. Steel studs to be min. 2-1/2 in. (64 mm) wide and spaced max. 24 in. (610 mm) OC.
 - B. **Gypsum Board*** - Two layers of nom 5/8 in. (16 mm) thick gypsum board, as specified in the individual Wall and Partition Design. Max. dia. of opening is 9-7/8 in. (251 mm).
2. **Through Penetrants** - One metallic pipe, conduit or tubing to be installed within the firestop system. An annular space of min. 0 in. to max. 7/8 in. (22 mm) is required within the firestop system. Pipe, conduit or tubing to be rigidly supported on both sides of floor or wall assembly. The following types and sizes of metallic pipes, conduits or tubing may be used:
 - A. **Steel Pipe** - Nom. 8 in. (203 mm) dia. (or smaller) Schedule 10 (or heavier) steel pipe.
 - B. **Iron Pipe** - Nom. 8 in. (203 mm) dia. (or smaller) cast or ductile iron pipe.
 - C. **Conduit** - Nom. 4 in. (102 mm) dia. (or smaller) steel electrical metallic tubing (EMT) or nom 6 in. (152 mm) dia. (or smaller) rigid steel conduit.
 - D. **Copper Tubing** - Nom. 4 in. (102 mm) dia. (or smaller) Type L (or heavier) copper tubing.
 - E. **Copper Pipe** - Nom. 4 in. (102 mm) dia. (or smaller) Regular (or heavier) copper pipe.
3. **Firestop System** - The firestop system shall consist of the following:
 - A. **Packing Material** - Min. 1/2 in. (13 mm) thickness of min. 4 pcf (64 kg/m³) mineral wool batt insulation firmly packed into opening as a permanent form. Packing material to be recessed from both surfaces of wall as required to accommodate the required thickness of fill material.
 - B. **Fill, Void or Cavity Material* - Sealant** — Min. 1/2 in. (13 mm) thickness of fill material applied within the annulus, flush with both surfaces of wall.
A/D FIRE PROTECTION SYSTEMS INC - A/D FIREBARRIER Intumescent Sealant or A/D FIREBARRIER Acrylic Sealant

*Bearing the UL Classification Mark