

Through-penetration Firestop Systems
ULSystem No. W-L-3322
F Ratings - 1 and 2 Hr (See Item 1)
T Ratings - 0, 1/4 and 1/2 Hr (See Items 2, 2A and 2B)
L Rating at Ambient - 16 CFM/sq ft

Configuration A

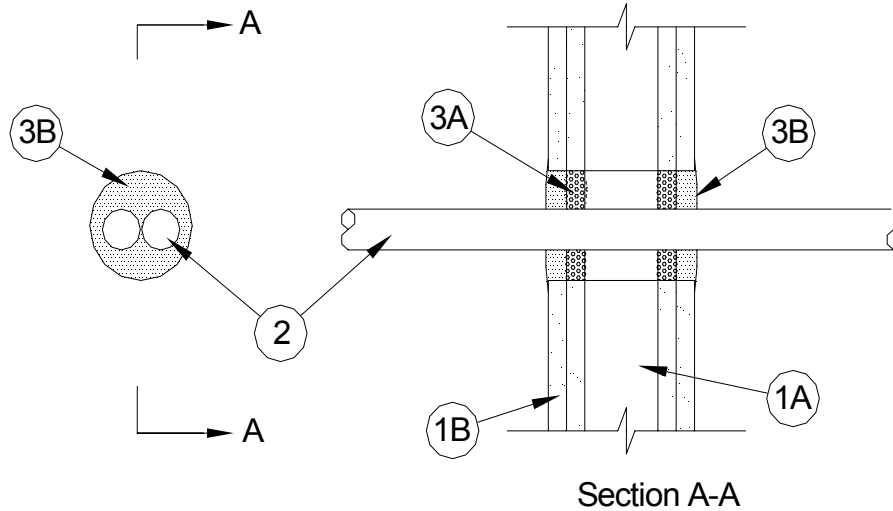

Configuration B

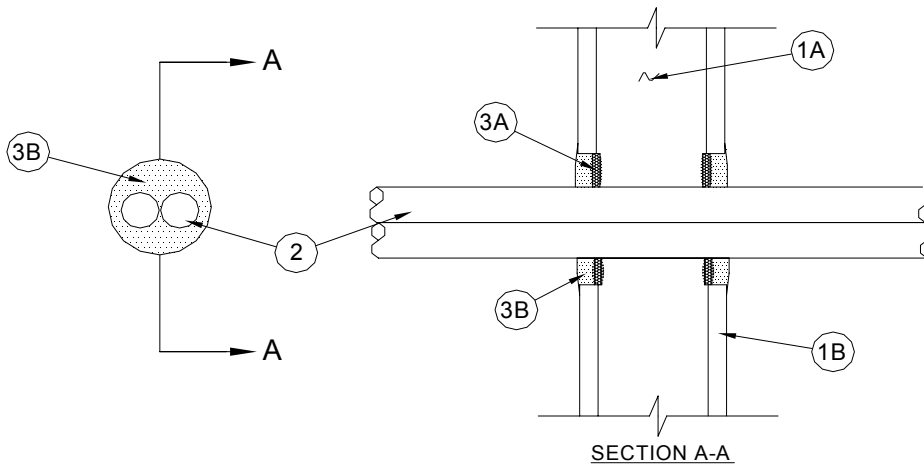

1. **Wall Assembly** - The 1 or 2 h fire-rated gypsum board/stud wall assembly shall be constructed of the materials and in the manner specified in the individual U300, U400 or V400 Series Wall and Partition Designs in the UL Fire Resistance Directory and shall include the following construction features:

- A. **Studs** - Wall framing may consist of either wood studs or steel channel studs. Wood studs to consist of nom 2 by 4 in. (51 by 102 mm) lumber spaced 16 in. (406 mm) OC. Steel studs to be min. 2-1/2 in. (64 mm) wide and spaced max. 24 in. (610 mm) OC.

UL System W-L-3322 continued...

B. **Gypsum Board*** - One or two layers of nom 5/8 in. (16 mm) thick gypsum board as specified in the individual Wall and Partition Design. Max. dia. of opening is 5 in. (127 mm).

The hourly F Rating of the firestop system is equal to the hourly fire rating of the wall assembly in which it is installed. The T Ratings are 1/4 and 1/2 hr when installed in 1 hr and 2 hr rated walls, respectively.

- 1A. **Steel Sleeve** - (Optional. Not shown.) Cylindrical sleeve fabricated from min 0.013 in. (0.330 mm) thick (No. 30 gauge) to max. 0.056 in. (1.42 mm) (No. 16 gauge) galv steel sheet and having a min. 1 in. (25 mm) lap along the longitudinal seam. Ends of sleeve to be flush with both surfaces of wall. Cylindrical sleeve to be installed by coiling the sheet metal to a dia. smaller than the through opening, inserting the coil through the opening and releasing the coil to let it uncoil against the circular cutout in the wall.
2. **Cables** - Max. two service entrance cables, as described below to be installed either concentrically or eccentrically within the firestop system. Cables to be rigidly supported on both sides of wall assembly. The following types and sizes of cables may be used:
- A. Max. four aluminum conductor No. 2/0 AWG (or smaller) Type SER service entrance cable with cross-linked polyethylene insulation and PVC jacket. Max two cables bundled together within the firestop system. The annular space between the cables and the periphery of opening shall be min. 1/2 in. (13 mm) to max. 1-1/2 in. (38 mm).
- B. Max. four aluminum conductor No. 2/0 AWG (or smaller) aluminum **Metal Clad Cable+** - Max one metal clad cable within the firestop system. The dia. of the opening shall be 1-1/4 in. (32 mm) greater then the dia. of the penetrant. The annular space between the cable and the periphery of opening shall be min. 1/4 in. (6 mm) to max. 1 in. (25 mm).

AFC CABLE SYSTEMS INC

When cables in Item 2 are used, the T Ratings are 1/4 and 1/2 hr when installed in 1 hr and 2 hr rated walls, respectively.

- 2A. **Through Penetrating Product*** - (Not Shown) As an alternate to Item 2, max. one through-penetrating product to be installed either concentrically or eccentrically within the opening. The annular space between through-penetrating product and periphery of opening is min. 1/4 in. (6 mm) to max 1 in. Through-penetrating product to be rigidly supported on both sides of wall assembly. The following types of through-penetrating products may be used:
- A. Max. four aluminum conductors No. 2/0 AWG (or smaller) aluminum **Armored Cable+** or **Metal-Clad Cable+**.
- AFC CABLE SYSTEMS INC**
- B. Two or more twisted copper conductors No. 6 AWG (or smaller) **Power Limited Circuit Cable+** with or without a jacket under a metal armor.
- AFC CABLE SYSTEMS INC**
- C. Two or more twisted copper conductors No. 10 AWG (or smaller) **Power Limited Fire Alarm Cable+** with or without a jacket under a metal armor.
- AFC CABLE SYSTEMS INC**
- D. Two or more twisted copper conductors No. 12 AWG (or smaller) **Non Power Limited Fire Alarm Cable+** with or without a jacket under a metal armor.
- AFC CABLE SYSTEMS INC**

When cables in Item 2A are used, the T Ratings are 1/4 and 1/2 hr when installed in 1 hr and 2 hr rated walls, respectively.

UL System W-L-3322 continued...

2B. **Cables** -(Not Shown) As an alternate to Items 2 and 2A, aggregate cross-sectional area of cables to be max. 45 percent of the cross-sectional area of the opening. Tight bundle of cables to be installed either concentrically or eccentrically within the opening. The dia. of the opening shall be 1 in. (25 mm) larger than the penetrant. The annular space between cable bundle and periphery of opening shall be min. 0 in. (point contact) to max. 1 in. (25 mm). Cables to be rigidly supported on both sides of wall assembly. Any combination of the following types and sizes of cables may be used:

- A. Max. 4 pair No. 24 AWG (or smaller) copper conductor data cable with Mylar jacket and insulation.
- B. Max. three conductor No. 12 AWG (or smaller) MC (BX) copper cable with polyvinyl chloride insulation and jacket materials.
- C. Max. 3/C with ground No. 8 AWG (or smaller) copper conductor NM cable (Romex) with PVC insulation and jacket.
- D. **Through Penetrating Product*** - Max. 4/C plus ground No. 12 AWG (or smaller) aluminum or steel clad **Metal Clad Cable+** with copper conductors.

ALFLEX CORP

- E. **Through Penetrating Product*** - Nom. 3/4 in. dia. (or smaller) aluminum or steel **Flexible Metal Conduit+** with electrical conductors as permitted by the National Electrical Code (NFPA 70).

ALFLEX CORP

When cables in Item 2B are used, the T Ratings are 0 and 1/4 hr when installed in 1 hr and 2 hr rated walls, respectively.

3. **Firestop System** - The firestop system shall consist of the following:

- A. **Packing Material** - (Optional) - Foam backer rod firmly packed into opening as a permanent form. Packing material to be recessed from both surfaces of wall as required to accommodate the required thickness of fill material.
- B. **Fill, Void or Cavity Material* - (Caulk)** - Min. 5/8 in. (16 mm) thickness of fill material applied within the annulus, flush with both surfaces of wall. Additional fill material to be installed such that a min. 3/8 in. (10 mm) crown is formed around the penetrating item and lapping 3/8 in. beyond the periphery of the opening. For cable bundle, additional fill material to be forced into interstices of cables to max. extent possible.

A/D FIRE PROTECTION SYSTEMS INC - A/D FIREBARRIER Intumescent Sealant

+Bearing the UL Listing Mark

*Bearing the UL Classification Marking