

UL System No. C-AJ-5027

(Formerly System No. 599)

F Rating — 3 Hr

T Rating — 3/4 Hr

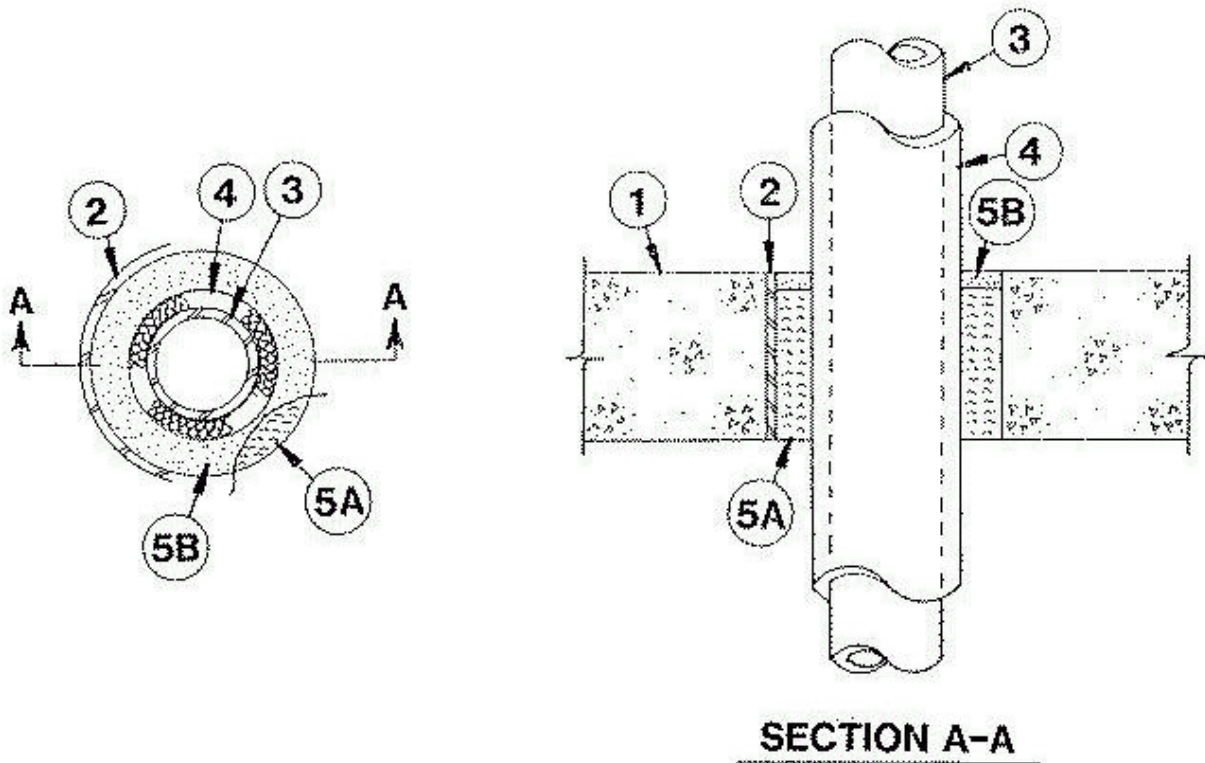

1. **Floor or Wall Assembly** Min 4-1/2 in. thick reinforced lightweight or normal weight (100-150 pcf) concrete. Wall may also be constructed of any UL Classified **Concrete Blocks***. Max dia. of opening is 6-5/8 in.

See **Concrete Blocks** (CAZT) category in the Fire Resistance Directory for names of manufacturers.

2. **Metallic Sleeve** (Optional) — Nom 6 in. dia. (or smaller) Schedule 40 steel pipe cast or grouted into floor or wall assembly, flush with floor or wall surfaces.

3. **Through Penetrants** One metallic pipe or tubing to be centered within the firestop system. Pipe or tubing to be rigidly supported on both sides of floor or wall assembly. The following types and sizes of metallic pipes or tubing may be used:

A. **Steel Pipe** Nom 3 in. dia. (or smaller) Schedule 5 (or heavier) steel pipe.

B. **Copper Tubing** Nom 3 in. dia. (or smaller) Type L (or heavier) copper tubing.

C. **Copper Pipe** Nom 3 in. dia. (or smaller) Regular (or heavier) copper pipe.

continued...

4. **Pipe Coverings*** The following types of pipe coverings may be used:

A. **Pipe and Equipment Covering — Materials*** Nom 1 in. thick hollow cylindrical heavy density (min 3.5 pcf) glass fiber units jacketed on the outside with an all service jacket. Longitudinal joints sealed with metal fasteners or factory-applied self-sealing lap tape. Transverse joints secured with metal fasteners or with butt tape supplied with the product. A nom. annular space of 1/4 in. is required within the firestop system.

See **Pipe and Equipment Covering — Materials** (BRGU) category in the Building Materials Directory for names of manufacturers. Any pipe covering material meeting the above specifications and bearing the UL Classification Marking with a Flame Spread Index of 25 or less and a Smoke Developed Index of 50 or less may be used.

B. **Pipe Coverings Materials*** Nom 1 in. thick unfaced mineral fiber pipe insulation having a nom density of 3.5 pcf (or heavier) and sized to the outside dia. of pipe or tube. Pipe insulation secured with min 8 AWG steel wire spaced max 12 in. OC. A nom annular space of 1/4 in. is required within the firestop system.

OWENS CORNING HT INC, DIV OF

OWENS CORNING — High Temperature Pipe Insulation 1200, High Temperature Pipe Insulation BWT or High Temperature Pipe Insulation Thermaloc

C. **Sheathing Materials*** (Not Shown) — Used in conjunction with Item 4B. Foil-scrim-kraft or all service jacket material shall be wrapped around the outer circumference of the pipe insulation (Item 3B) with the kraft side exposed. Longitudinal joints and transverse joints sealed with metal fasteners or with butt tape.

See **Sheathing Materials** (BVDV) category in the Building Materials Directory for names of manufacturers. Any sheathing material meeting the above specifications and bearing the UL Classification Marking with a Flame Spread Index of 25 or less and a Smoke Developed Index of 50 or less may be used.

5. **Firestop System** The firestop system shall consist of the following:

A. **Packing Material** Min 4 in. thickness of min 4 pcf mineral wool batt insulation firmly packed into opening as a permanent form. Packing material to be recessed from top surface of floor or from both surfaces of wall as required to accommodate the required thickness of fill material.

B. **Fill, Void or Cavity Material*** — **Caulk** Min 1/2 in. thickness of fill material applied within the annulus, flush with top surface of floor or with both surfaces of wall.

A/D FIRE PROTECTION SYSTEMS INC — A/D FIREBARRIER Silicone Sealant [S/L (floors only) or G/G (floor or walls)].

*Bearing the UL Classification Marking