

UL System No. C-AJ-8029

(Formerly System No. 622)

F Rating — 3 Hr

T Rating — 0 Hr

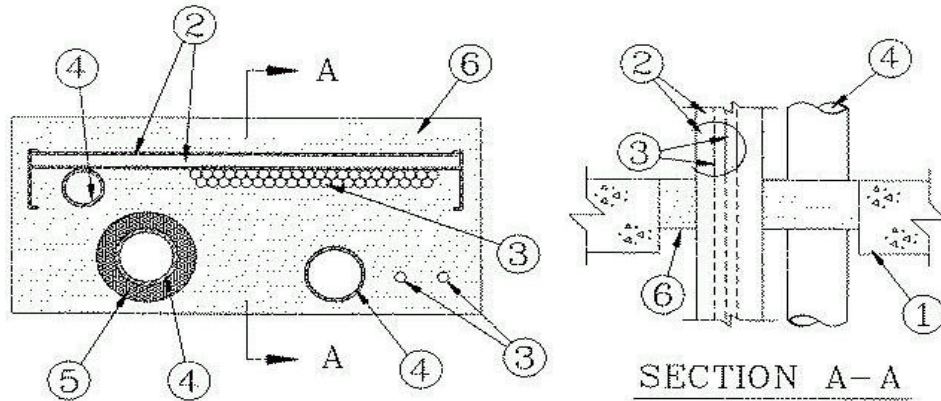

1. **Floor or Wall Assembly** Min 4-1/2 in. thick reinforced normal weight (140-150 pcf) concrete. Wall may also be constructed of any UL Classified **Concrete Blocks***. Floor may also be constructed of any min 8 in. thick UL Classified hollow core **Precast Concrete Units***. Max area of opening is 312 sq in. with max dimension of 28 in. If the firestop system is installed within a hollow-core precast concrete unit, the max area of opening is 49 sq in. with max dimension of 7 in.

See **Concrete Blocks** (CAZT) and **Precast Concrete Units** (CFTV) categories in the Fire Resistance Directory for names of manufacturers.

2. **Cable Tray*** Max 24 in. wide by max 4 in. deep open ladder cable tray with channel-shaped side rails formed of min 0.065 in. thick steel with 3 in. wide by 1/2 in. deep rungs spaced 14-1/2 in. OC. One cable tray to be installed in the opening. The annular space between the cable tray and the periphery of the opening shall be min 1 in. to max 6 in. Cable tray to be rigidly supported on both sides of floor or wall assembly.

3. **Cables** Aggregate cross-sectional area of cables in cable tray to be max 40 percent of the cross sectional area of the tray based on a max 3 in. cable loading depth within the cable tray. Any combination of the following types of copper conductor cables may be used:

A. Max 1/C-500 kcmil (or smaller) cable with cross-linked polyethylene insulation and jacket.

B. Max of 100 pair No. 24 AWG telephone cable with polyvinyl chloride (PVC) insulation and jacket.

C. Max RG 11/U coaxial cable (or smaller) with fluorinated ethylene propylene insulation and jacket.

D. Max 2/C-No. 12 AWG (or smaller) cable with (PVC) insulation and jacket.

C-AJ-8029 continued...

In addition, a max of two cables may be installed outside the cable tray. The cables shall be spaced a nom 2 in. apart and a nom 2 in. from the periphery of the opening. The cable shall be spaced a min 2 in. to max 4 in. from the other through penetrants (Item Nos. 2, 4 and 5). Cables to be rigidly supported on both sides of floor or wall assembly.

4. **Through-Penetrants** Two pipes, conduits or tubes to be installed within the opening. The space between pipes, conduits or tubes shall be a nom 6-3/4 in. The space between pipes, conduits or tubes and periphery of opening shall be min 1-1/2 in. to max 6-1/2 in. Pipes, conduits or tubes shall be spaced a min 2 in. to a max 4 in. from the other through penetrants (Item Nos. 2, 3 and 5). Pipes, conduits or tubes to be rigidly supported on both sides of floor or wall assembly. The following types and sizes of metallic pipes, conduits or tubes may be used:

- A. **Steel Pipe** Nom 3 in. dia. (or smaller) Schedule 40 (or heavier) steel pipe.
- B. **Iron Pipe** Nom 3 in. dia. (or smaller) cast or ductile iron pipe.
- C. **Conduit** Nom 3 in. dia. (or smaller), steel electrical metallic tubing or steel conduit.
- D. **Copper Tubing** Nom 3 in. dia. (or smaller) Type M (or heavier) copper tubing.
- E. **Copper Pipe** Nom 3 in. dia. (or smaller) Regular (or heavier) copper pipe.

In addition, one nom 2 in. dia. (or smaller) steel electrical metallic tubing or steel conduit may be installed within the cable tray (Item 2). The conduit or tubes shall be spaced a nom 1 in. from the side rail of the cable tray and a min 1 in. from the cable bundles.

5. **Pipe Covering*** The following types of pipe coverings may be used on the steel pipe (Item 4A):

A. **Pipe and Equipment Covering — Materials*** Nom 1 in. thick hollow cylindrical heavy density (min 3.5 pcf) glass fiber units jacketed on the outside with an all service jacket. Longitudinal joints sealed with metal fasteners or factory-applied self-sealing lap tape. Transverse joints secured with metal fasteners or with butt tape supplied with the product.

See **Pipe and Equipment Covering — Materials** (BRGU) category in the Building Materials Directory for names of manufacturers. Any pipe covering material meeting the above specifications and bearing the UL Classification Marking with a Flame Spread Index of 25 or less and a Smoke Developed Index of 50 or less may be used.

B. **Pipe Covering Materials*** Nom 1 in. thick unfaced mineral fiber pipe insulation having a nom density of 3.5 pcf (or heavier) and sized to the outside dia. of pipe or tube. Pipe insulation secured with min 8 AWG steel wire spaced max 12 in. OC.

C-AJ-8029 continued...

OWENS CORNING HT INC, DIV OF

OWENS CORNING — High Temperature Pipe Insulation 1200, High Temperature Pipe Insulation BWT or High Temperature Pipe Insulation Thermaloc

C. Sheathing Material* (Not Shown) — Used in conjunction with Item 5B. Foil-scrim-kraft or all service jacket material shall be wrapped around the outer circumference of the pipe insulation (Item 3B) with the kraft side exposed. Longitudinal joints and transverse joints sealed with metal fasteners or with butt tape.

See **Sheathing Materials** (BVDV) category in the Building Materials Directory for names of manufacturers. Any sheathing material meeting the above specifications and bearing the UL Classification Marking with a Flame Spread Index of 25 or less and a Smoke Developed Index of 50 or less may be used.

The space between the insulated pipe and the periphery of the opening shall be a min 1-1/2 in. to a max 6-1/2 in. The insulated pipe shall be a min 2 in. to a max 6-3/4 in. from the other through-penetrants (Item Nos. 2, 3 and 4).

6. Firestop System The firestop system shall consist of the following:

A. Forms (Not Shown) — Used as a form to prevent leakage of fill material during installation. Forms to be a rigid sheet material, cut to fit the contour of the penetrating item and friction fitted into the opening. Forms to be recessed from top surface of floor or both surfaces of wall as required to accommodate the required thickness of fill material. Forms to be removed after fill material has cured.

B. Fill, Void or Cavity Material* — **Mortar** Min 3 in. thickness of fill material installed flush with top surface of floor and both surfaces of wall. If **Pre-Cast Concrete Units*** (Item 1) are used, hollow core within the units are to be back filled with a min 4 in. thickness of fill material. Fill material to be mixed at a rate of 2.7 parts dry mixture to one part water by weight in accordance with the installation instructions supplied with the product.

A/D FIRE PROTECTION SYSTEMS INC — A/D FIREBARRIER Mortar.

*Bearing the UL Classification Marking