

**UL System No. HW-D-1020**  
**Assembly Rating — 1 and 2 Hr (See Item 2)**  
**Nominal Joint Width — 3 in.**

**Class II and III Movement Capabilities — 100% Compression or Extension**

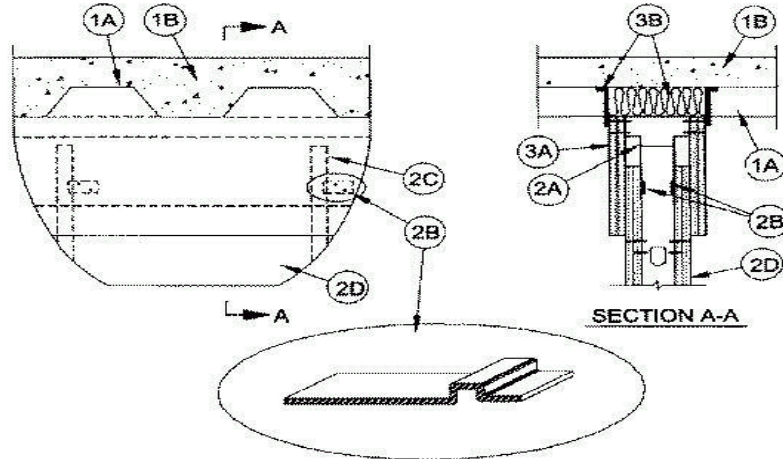

**CONFIGURATION A**

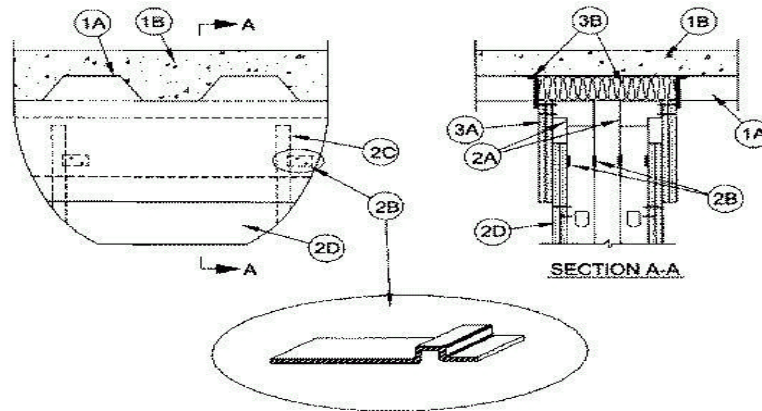

**CONFIGURATION A1**

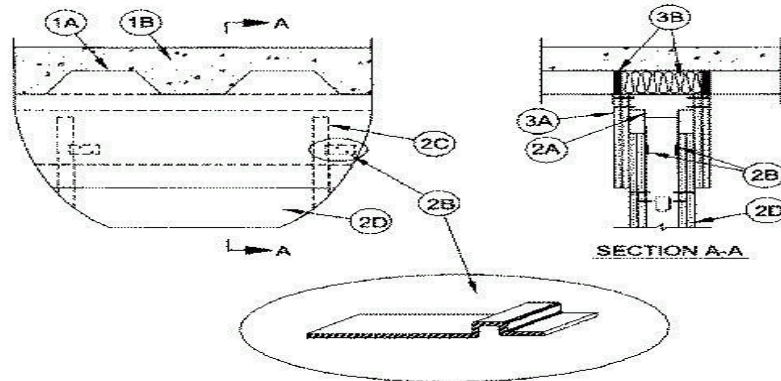

**CONFIGURATION B**

## UL Design System HW-D-1020 continued...

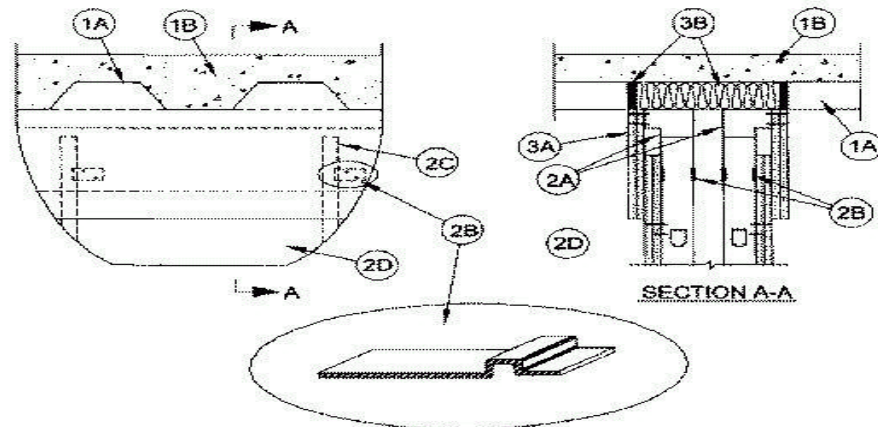

### CONFIGURATION B1

1. **Floor Assembly** The fire-rated fluted steel deck/concrete floor assembly shall be constructed of the materials and in the manner described in the individual Floor-Ceiling Design in the UL Fire Resistance Directory. The hourly fire rating of the floor assembly shall be equal to or greater than the hourly fire rating of the wall assembly. The floor assembly shall include the following construction features:

- A. **Steel Floor and Form Units\*** Max. 3 in. deep galv. fluted floor units.
- B. **Concrete** Min. 2-1/2 in. thick reinforced (100-150 pcf) concrete, as measured from the top plane of the floor units.

1A. **Roof Assembly** As an alternate to Item 1, the fire-rated roof assembly shall be constructed of the materials and in the manner described in the individual P900 Series Roof-Ceiling Designs in the UL Fire Resistance Directory and shall contain max. 3 in. deep galv. steel fluted roof units. The hourly fire rating of the assembly shall be equal or greater than the hourly fire rating of the wall assembly. In the case of spray-applied protection materials in the steel roof units, the joint system shall be installed prior to the spray-applied protection material.

1B. **Floor Assembly** As an alternate to Item 1, min. 4-1/2 in. thick reinforced lightweight or normal weight (100-150 pcf) structural concrete.

2. **Wall Assembly** The 1 or 2 hr fire-rated gypsum board /steel stud wall assembly shall be constructed of the materials and in the manner described in the individual U400 and V400-Series Wall and Partition Design in the UL Fire Resistance Directory and shall include the following construction features:

- A. **Light Gauge Framing\* — Deflection Trak** Deflection trak of wall assembly shall consist of min. No. 25 gauge galv steel channels sized to accommodate steel studs (Item 2C) and with offset legs to accommodate wall cladding (Item 3A). Deflection trak installed perpendicular to floor units. Min. No. 25 gauge deflection trak secured on both sides to valley of floor units with 1-1/2 in. long welds spaced max. 12 in. OC. Min. No. 20 gauge deflection trak may be secured with steel fasteners spaced 12 in. OC.

**FIRE TRAK CORP** — Shadowline and Cavity Shadowline

- B. **Slip Clip** Slip Clips are attached to the inside bottom leg of the ceiling runner (Item 2A) with 2 - No. 8 by 1/2 in. long steel self-drilling framing screws and engage the short flange of the studs.

**FIRE TRAK CORP** — Slip Clips

## UL Design System HW-D-1020 continued...

C. **Studs** Steel studs to be min. 2-1/2 in. wide and as specified in the individual Wall and Partition Design in the UL Fire Resistance Directory. Studs cut 4 in. less in length than the assembly height with bottom nesting in and resting on floor runner and with top nesting in ceiling runner without attachment. Stud spacing not to exceed 24 in. OC.

D. **Gypsum Board\*** Gypsum board sheets installed and attached to studs and runners as specified in the individual Wall and Partition Design in the UL Fire Resistance Directory, except that a nominal 3-1/2 in. gap shall be maintained between top of the gypsum board and the bottom flange of the deflection trak. Top row of screws shall be installed into the studs 13-1/2 in. below the top edge of the gypsum board sheets.

E. **Bracing** (Not shown) Bracing as specified in the individual Wall and Partition Design in the UL Fire Resistance Directory.

**The hourly assembly rating of the joint is equal to the fire rating of the wall.**

### Firestop Configuration A and A1

**3. Joint System- Max. separation between bottom flange of the deflection trak and top of wallboard (at the time of installation of the joint system) is 1 in. The joint system is designed to accommodate a max. 100 percent compression or extension from its installed width.** The joint system consists of spray applied fire resistive material (Item 3A), and wall cladding (Item 3B) as follows:

A. **Wall Cladding** Strips of the gypsum wallboard material attached to the deflection trak. The number of layers, board type and thickness and fastener type shall be as specified for the gypsum board in the individual Wall and Partition Design in the UL Fire Resistance Directory. Fasteners shall be max. spaced 3 in. OC. The top of the wall cladding shall be flush with the valleys of the steel floor units and overlap the gypsum board 7 in.

B. **Flute Fill** The batt insulation and fill material are to be installed as specified in the Joint Systems in the table below:

Manufacturer	Product Designation	System No.
A/D Fire Protection Systems Inc.	A/D FireBarrier Seal N/S	HW-D-0247
Firestop Systems Inc.	5100SP	HW-D-0025
Hilti Construction Chemicals	CP 672 Fire Spray	HW-D-0042
International Protective Coatings	FS3000	HW-D-0108
Johns Manville International	Firetemp SI, Firetemp SE	HW-D-0047
Minnesota Mining & Mfg.	FireDam™ Spray 100, FireBarrier Spray 100	HW-D-0020
Nelson Firestop Products	FSC-Firestop Coating	HW-D-0112
Rectorseal	Biostop 700	HW-D-0019
Rectorseal	Biostop 750 Spray, Biostop 750 Caulk Grade	HW-D-0033
Rectorseal	Metacaulk 1100	HW-D-0018
Rectorseal	Metacaulk 1200 Spray, Metacaulk 1200 Caulk Grade	HW-D-0032
Specified Technologies Inc.	SpecSeal AS 200 Spray	HW-D-0054
Tremco	TREMstop Acrylic SP	HW-D-0091

**A/D FIRE PROTECTION SYSTEMS INC** — A/D FireBarrier Seal N/S

**PASSIVE FIRE PROTECTION PARTNERS** — 5100SP

**HILTI CONSTRUCTION CHEMICALS, DIV OF**

**HILTI INC** — CP 672 Fire Spray

**JOHNS MANVILLE INTERNATIONAL INC** — Firetemp SI, Firetemp SE

**3M COMPANY** — Fire Dam Spray

**UL Design System HW-D-1020 continued...**

**NELSON FIRESTOP PRODUCTS** — FSC-Firestop Coating  
**RECTORSEAL** — Metacaulk 1100, Metacaulk 1200 Spray, Metacaulk 1200 Caulk Grade, Biostop 700, Biostop 750 Spray, Biostop 750 Caulk Grade  
**SPECIFIED TECHNOLOGIES INC** — SpecSeal AS 200 Spray  
**TREMCO INC** — TREMstop Acrylic SP  
**W R GRACE & CO - CONN CONSTRUCTION PRODUCTS DIV** — FS3000

**Firestop Configuration B and B1**

**3. Joint System- Max. separation between bottom flange of the deflection trak and top of wallboard (at the time of installation of the joint system) is 1 in. The joint system is designed to accommodate a max. 100 percent compression or extension from its installed width.** The joint system consists of spray applied fire resistive material (Item 3A), and wall cladding (Item 3B) as follows:

**A. Wall Cladding** Strips of the gypsum board material attached to the deflection trak. The number of layers, board type and thickness and fastener type shall be as specified for the gypsum board in the individual Wall and Partition Design in the UL Fire Resistance Directory. Fasteners shall be max. spaced 3 in. OC. The top of the wall cladding shall be flush with the valleys of the steel floor units and overlap the gypsum board 7 in.

**B. Flute Fill** The batt insulation and fill material are to be installed as specified in the Joint Systems in the table below:

Manufacturer	Product Designation	System No.
A/D Fire Protection Systems Inc.	A/D FireBarrier Seal N/S	HW-D-0247
DAP Inc.	DAP Firestop Sealant	HW-D-0026
Hilti Construction Chemicals	FS611A	HW-D-0003
Hilti Construction Chemicals	FS-ONE	HW-D-0003
Hychem USA, Inc.	Firestop 600	HW-S-0046
Instant Firestop Mfg.	344-GG	HW-S-0008
Minnesota Mining & Mfg.	FB 1000NS	HW-S-0028
Minnesota Mining & Mfg.	FB 2000	HW-S-0002
Minnesota Mining & Mfg.	FB 2000+	HW-S-0002
Nuco Inc.	Self Seal GG200	HW-S-0011
Rectorseal	Metacaulk 835+	HW-S-0023
Rectorseal	Metacaulk 1000	HW-D-0014
Rectorseal	Biostop 500+	HW-D-0015
Rectorseal	Biotherm 1000	HW-S-0022
Specified Technologies Inc.	SpecSeal ES	HW-D-0034
United States Gypsum Co.	RFC	HW-S-0001

**A/D FIRE PROTECTION SYSTEMS INC** — A/D FireBarrier Seal N/S  
**DAP INC** — DAP Firestop Sealant  
**HILTI CONSTRUCTION CHEMICALS, DIV OF HILTI INC** — FS611A or FS-ONE  
**3M COMPANY** — FB 1000NS, FB 2000, FB 2000+  
**NUCO INC** — Self Seal ES 100 Sealant  
**NELSON FIRESTOP PRODUCTS** — FSC-Firestop Coating  
**RECTORSEAL** — Metacaulk 835+, Metacaulk 1000, Biostop 500+ Caulk, Biotherm 100  
**SPECIFIED TECHNOLOGIES INC** — SpecSeal ES Sealant  
**UNITED STATES GYPSUM CO** — RFC

\*Bearing the UL Classification Mark