

UL - Through-penetration Firestop Systems Certified for Canada

UL System No. W-J-2141

November 25, 2003

F Ratings — 1 or 2 Hr (See item 3)
FT Ratings — 0, 3/4 or 1 Hr (See item 3)
FH Ratings — 1 or 2 Hr (See item 3)
FTH Ratings — 0, 3/4 or 1 Hr (See item 3)

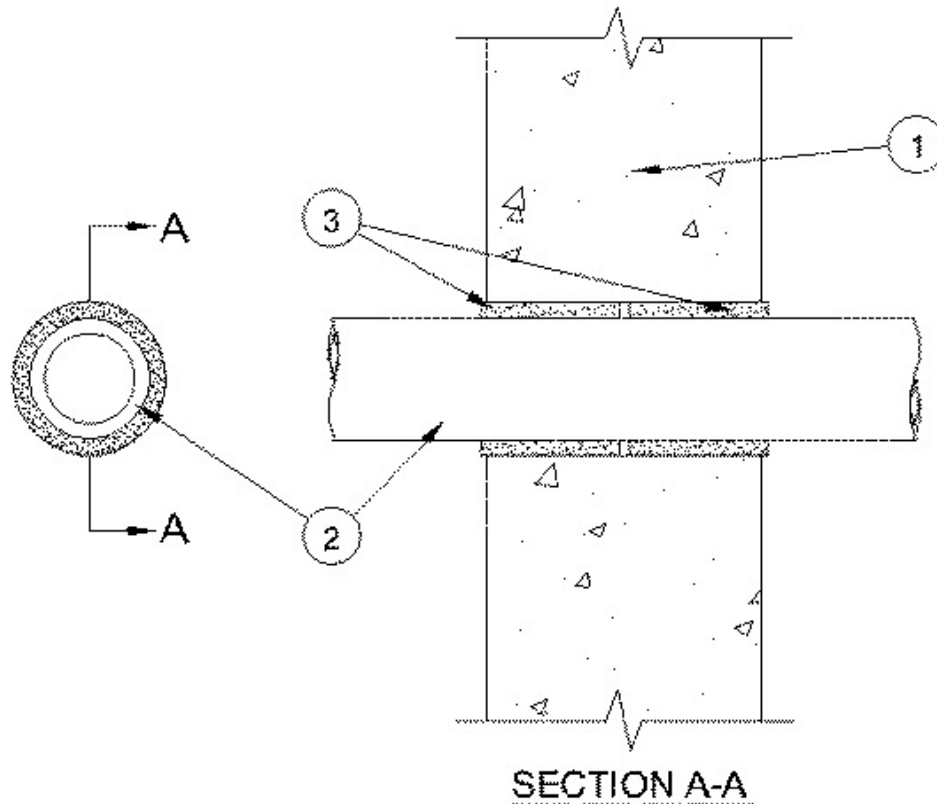

System tested with a pressure differential of **50 Pa** between the exposed and the unexposed surfaces with the higher pressure on the exposed side.

1. Wall Assembly — Reinforced lightweight or normal weight 1600-2400 kg/m³ (100-150 pcf) concrete. The thickness of the wall assembly shall be as shown in the table under Item 3. Wall may also be constructed of any UL Classified **Concrete Blocks***. Max diam of opening is 92 mm (3-5/8 in.)

See **Concrete Blocks** (CAZT) category in the Fire Resistance Directory for names of manufacturers.

2. Through Penetrants — One nonmetallic pipe to be positioned within a nom 8 to 16 mm (5/16 to 5/8 in.) range of annular space within the firestop system when one or two layers of wrap strip are used, respectively. Pipe to be rigidly supported on both sides of wall assembly. The following types and sizes of nonmetallic pipes or conduits may be used:

A. Polyvinyl Chloride (PVC) Pipe — Nom 51 mm (2 in.) diam (or smaller) Schedule 40 solid core PVC pipe for use in vented (drain, waste or vent) piping systems. Nom 38 mm

(1-1/2 in.) diam (or smaller) Schedule 40 cellular or solid core PVC pipe for use in vented (drain, waste or vent) piping systems.

B. Cross Linked Polyethylene (PEX) Tubing — Nom. 25 mm (1 in.) diam (or smaller) SDR 9 PEX tubing for use in closed (process or supply) piping systems.

C. Acrylonitrile Butadiene Styrene (ABS) Pipe — Nom 51 mm (2 in.) diam (or smaller) Schedule 40 cellular or solid core ABS pipe for use in vented (drain, waste or vent) piping systems.

3. Firestop System — The firestop system shall consist of the following:

A. Fill, Void or Cavity Material* - Wrap Strip — One two layer of nom 6 mm (1/4 in.) thick by 51mm (2 in.) wide or 1 or 2 layers of nom 6 mm (1/4 in.) thick by 25 mm (1 in.) wide wrap strip wrapped around the outer circumference of the pipe and secured with tape or wire and wrap strip slid into annular space such that the ends are flush with or extend a max of 3 mm (1/8 in.) beyond the surface of the wall. Wrap strips are installed on each surface of the wall. The F, FT, FH and FTH Ratings are dependent upon the pipe type, the nom pipe diam, the wall thickness, the wrap strip width and the number of wrap strip layers, as shown in the following table.

Pipe Type	Nom Pipe Diam mm (in.)	Min Wall Thkns mm (in.)	Wrap Strip Width mm (in.)	Min Wrap Strip Layers	F Rating Hr	FT Rating Hr	FH Rating Hr	FTH Rating Hr
PVC Solid Core	0 to 51 (0 to 2)	152 (6)	25 (1)	2	2	1	2	1
PVC Solid or Cellular Core	0 to 38 (0 to 1-1/2)	114 (4-1/2)	25 (1)	1	1	3/4	1	3/4
PEX	0 to 25 (0 to 1)	114 (4-1/2)	25 (1)	1	1	1	1	1
ABS	51 (2)	152 (6)	51 (2)	1	2	0	2	0

A/D FIRE PROTECTION SYSTEMS INC — A/D FIREBARRIER Wrap Strip

*Bearing the UL Classification Mark