

UL System No. W-L-2350

July 07, 2003

F Ratings — 1 and 2 Hr (See Item 1)

T Rating — 0 Hr

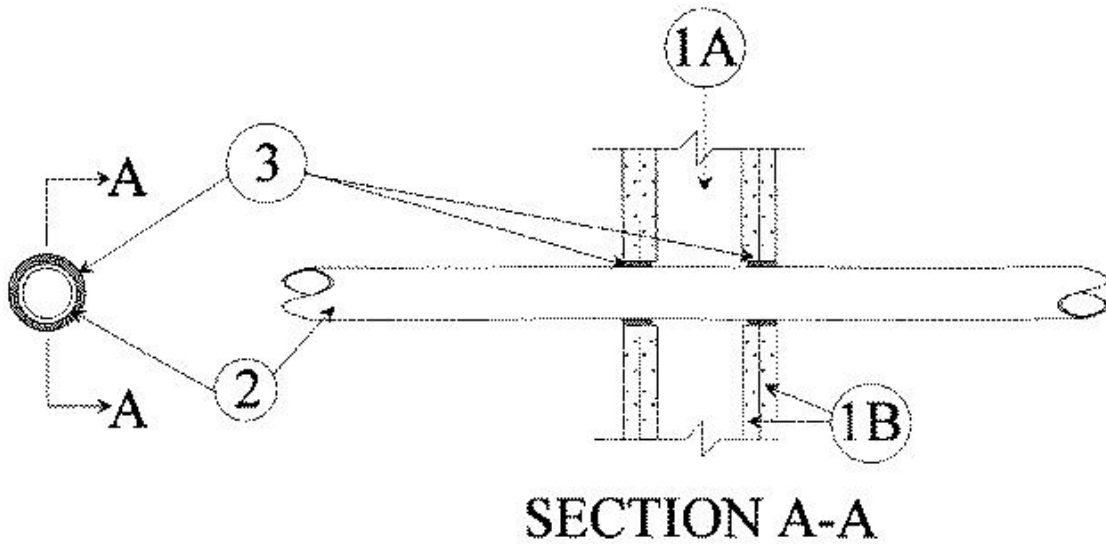

1. Wall Assembly — The 1 or 2 hr fire-rated gypsum wallboard/stud wall assembly shall be constructed of the materials and in the manner specified in the individual U300 or U400 Series Wall and Partition Designs in the UL Fire Resistance Directory and shall include the following construction features:

A. Studs — Wall framing may consist of either wood studs or steel channel studs. Wood studs to consist of nom 2 by 4 in. lumber spaced 16 in. OC. Steel studs to be min 2-1/2 in. wide and spaced max 24 in. OC.

B. Gypsum Board* — Min 5/8 in. thick, 4 ft wide with square on tapered edges. The gypsum wallboard type, thickness, number of layers and orientation shall be as specified in the individual Wall and Partition Design. Max diam of opening is 3 in.

The hourly F rating of the firestop system is equal to the hourly fire rating of the wall assembly in which it is installed.

2. Through Penetrants — One nonmetallic pipe or tube to be centered within the firestop system with a nom 5/16 in. annular space. Pipe or tube to be rigidly supported on both sides of wall assembly. The following types and sizes of pipes may be used:

A. Polyvinyl Chloride (PVC) Pipe — Nom 2 in. diam (or smaller) Schedule 40 cellular or solid core PVC pipe for use in closed (process or supply) or vented (drain, waste or vent) piping systems.

B. Acrylonitrile Butadiene Styrene (ABS) Pipe — Nom 2 in. diam (or smaller) Schedule 40 cellular or solid core ABS pipe for use in closed (process or supply) or vented (drain, waste or vent) piping systems.

C. Chlorinated Polyvinyl Chloride (CPVC) Pipe — Nom 2 in. diam (or smaller) SDR 17 CPVC pipe for use in closed (process or supply) or vented (drain, waste or vent) piping systems.

D. Crosslinked Polyethylene (PEX) Tubing — Nom 1 in. diam (or smaller) SDR 9 PEX tube for use in closed (process or supply) piping systems.

3. Fill, Void or Cavity Material* — Wrap Strip — Nom 1/4 in. thick by 1 in. wide intumescent wrap strip. The wrap strip is continuously wrapped around the outer circumference of the pipe once and slid into annular space such that the ends are flush with the surface of the wall. Wrap strips are installed on each surface of the wall.

A/D FIRE PROTECTION SYSTEMS INC — A/D FIREBARRIER Wrap Strip

*Bearing the UL Classification Mark