

ULC System No. HW67
F Rating — 2 h
FT Rating — 3/4 h
FH and FTH Ratings — 0 h
Nominal Joint Width — 100 mm

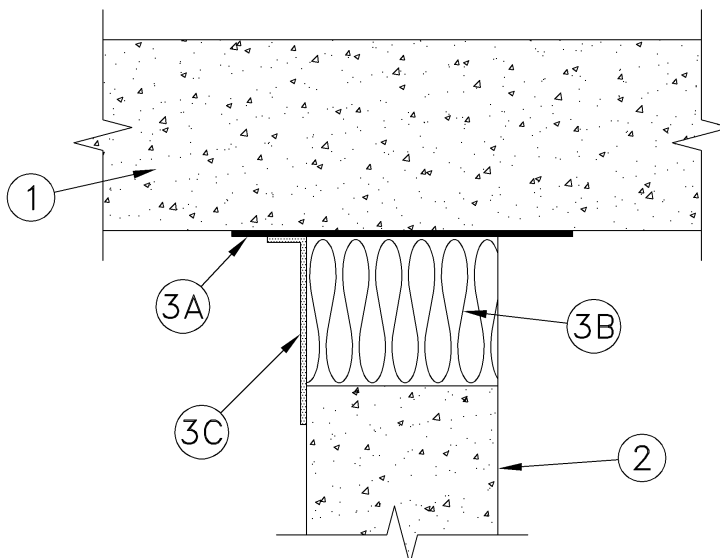

1. Floor Assembly — Minimum 64 mm thick reinforced low-density or normal-density (1600 to 2400 kg/m³) structural concrete.

2. Wall Assembly — Minimum 64 mm thick reinforced low-density or normal-density (1600 to 2400 kg/m³) structural concrete. Wall may also be constructed of nominal 200 mm thick concrete block.

3. Joint System — Maximum width (at time of installation of joint system) is 100 mm. The joint system shall consist of the following:

- (a) **Membrane** — (Optional) -UL or ULC Classified self-adhesive membrane designated Blueskin SA or SA-LT, cut to minimum 115 mm width and applied to either surface of joint. When membrane applied to bottom surface of floor, it shall extend a minimum of 25 mm beyond each face of joint. When membrane applied to wall, it shall overlap min 25 mm onto each surface of wall. Each adjoining length of membrane shall overlap previous length by 50 mm. Prior to application of membrane, Blueskin Primer applied to concrete surface at a minimum application rate of 0.2 kg/m².
- (b) **Firestop System Components** — XHJZC (Guide No. 40 U19.13). Minimum 64 mm thickness of minimum 64 kg/m³ "A/D FIREBARRIER Mineral Wool" batt insulation installed in joint opening as a permanent form. Pieces of batt cut into strips and installed edge-first into joint opening, parallel with joint direction, such that batt sections are compressed minimum 30% in thickness and that the compressed batt sections are flush with both surfaces of wall. Adjoining lengths of batt to be tightly-butted with butted seams spaced minimum 610 mm apart along the length of the joint.

A/D FIRE PROTECTION SYSTEMS INC

- (c) **Firestop System Components** — XHJZC (Guide No. 40 U19.13). Minimum 3.2 mm wet thickness of "A/D FIREBARRIER Seal N/S" sprayed or brushed to either surface of wall to completely cover mineral wool and overlapping a minimum 13 mm onto concrete surface on either side of joint.

A/D FIRE PROTECTION SYSTEMS INC