

ULC System No. SP624
 March 04, 2008
 F Rating - 2 h
 FH, FT and FTH Ratings - 0 h

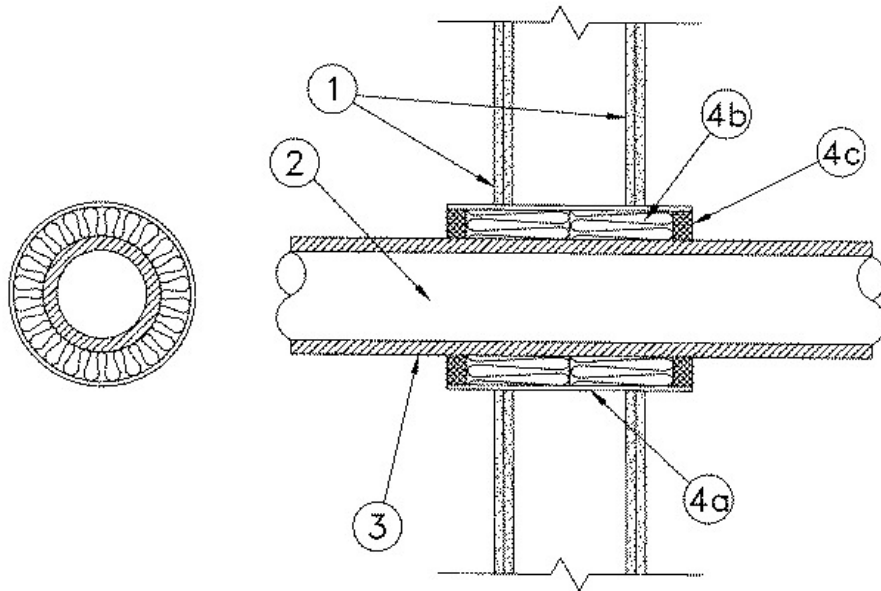

1. **Wall Assembly** - The fire-rated gypsum wallboard/stud wall shall be constructed of the materials and in the manner described in the individual wall and partition design in the ULC List of Equipment and Materials, Fire Resistance, Fire Resistance Ratings, and shall include the following construction features:
 - (a) **Studs** - Wall framing may consist of either wood studs or steel channel studs. Wood studs to consist of nominal 38 mm by 89 mm lumber spaced 406 mm OC. Steel studs to be minimum 63 mm wide and spaced maximum 610 mm OC.
 - (b) **Gypsum Wallboard** - Minimum 12.7 mm thick gypsum wallboard installed vertically in two layers both sides of stud framing with joints of each layer centred over studs. Inner layer joints on opposite sides of wall staggered one stud. Outer layer joints staggered one stud from inner layer joints.
 - (c) As an alternate to the gypsum wall assembly [Items 1(a) and 1(b)], wall may consist of minimum 114 mm thick poured concrete or concrete block wall.
2. **Pipes** - All pipes are rigidly supported and centred in the opening through the gypsum wallboard.
 - (a) Nominal 254 mm OD (maximum) Schedule 40 steel pipe.
 - (b) Nominal 152 mm OD (maximum) Schedule 40 steel pipe.
 - (c) Nominal 102 mm OD (maximum) copper pipe or steel conduit with minimum 2.5 mm wall thickness.
 - (d) Nominal 102 mm OD (maximum) copper pipe with minimum 2.5 mm wall thickness.

Type of Penetrating Item	F Rating, h	Annular Space, mm	Size of Through-Opening, mm
Item 2a steel pipe	2	12	305
Item 2b insulated steel pipe	2	38-44+	305
Item 2c copper pipe or steel conduit	2	19-25	152
Item 2d insulated steel pipe	2	44+	254

Note: +Distance from insulation to edge of through-opening.

ULC System SP624 continued...

3. **Pipe Insulation** - Copper or steel pipe (Items 2b, 2d) to be wrapped with nominal 25 mm thick ULC labelled pipe insulation, minimum density 56 kg/m³. No pipe insulation joints to be closer than 300 mm to wall surface.
4. **Firestop System** - Installed symmetrically on both sides of the wall assembly. The details of the firestop system shall be as follows:
 - (a) **Galvanized Steel Sleeve** - Cylindrical sleeve 0.95 mm thick by 215 mm long minimum having a minimum 50 mm lap along the longitudinal seam. The ends of the sleeve will project approximately 44 mm beyond each surface of the wall on both sides of the assembly. The sleeve is installed by coiling to a diameter smaller than the through-opening, inserting the coil through the openings, and releasing the coil to let it uncoil against the circular cutouts in the gypsum wallboard or concrete wall. For gypsum walls, the intersection of the wall and sleeve shall be finished with drywall tape and drywall compound. For concrete walls, sleeve/wall interface shall be grouted.
 - (b) **Firestop System Component** - XHJZC (Guide No. 40 U19.13). "A/D FIREBARRIER mineral wool" insulation, minimum 102 mm in depth, compressed minimum 33% and firmly packed into the sleeve on both sides of the wall assembly flush with the top and bottom of the sleeve.

A/D FIRE PROTECTION SYSTEMS INC
 - (c) **Firestop System Component** — XHJZC (Guide No. 40 U19.13). "A/D FIREBARRIER Sealant" caulked into the annular space to a minimum depth of 6 mm on both sides of assembly.

A/D FIRE PROTECTION SYSTEMS INC