

**ULC SYSTEM No. SP926
(For Vertical Separation)**

F and FH Ratings – 1 or 2 h (See Item 1)
FT and FTH Ratings – 0 h

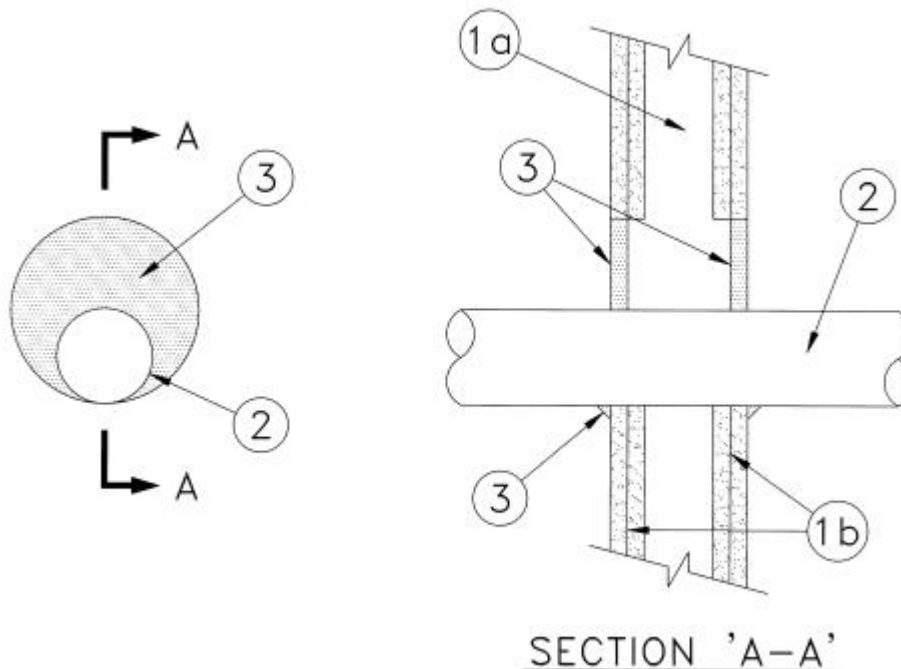

1. Wall Assembly – The 2 h or 1 h fire-rated gypsum wallboard/stud wall assembly shall be constructed of the materials and in the manner specified in the individual Wall or Partition designs in the Underwriters' Laboratories of Canada List of Equipment and Materials and shall include the following construction features:

(a) Studs – Wall framing may consist of either wood studs or steel channel studs. Wood studs to consist of nominal 50 mm by 102 mm lumber spaced 405 mm OC. Steel studs to be minimum 92 mm wide and spaced maximum 600 mm OC.

(b) Wallboard, Gypsum – Two layers for 2 h fire-rated, one layer for 1 h fire-rated, nominal 16 mm thick, 1220 mm wide with square or tapered edges. The gypsum wallboard type, fastener type and sheet orientation shall be as specified in the individual wall or partition design. Diameter of opening in wallboard layers to be 47.5 mm larger than outside diameter of pipe. Maximum diameter of opening in wallboard layers is 102 mm.

2. Metal Pipe – Nominal 51 mm diameter (or smaller) Schedule 10 (or heavier) steel pipe, cast or ductile iron pipe Type L (or heavier) copper pipe or steel electrical metallic tubing or steel conduit. One pipe to be installed either concentrically or eccentrically with the firestop system. The annular space between the pipe and the edge of the through-opening shall be minimum 0 mm (point contact) to maximum 47.5 mm. Pipe to be rigidly supported on both sides of wall assembly.

• **3. Firestop System Components** – (Guide No. 40 U19.13). Type "A/D Firebarrier Silicone" installed to fill the annular space to a depth of 16 mm representing the thickness of the outside layer of gypsum wallboard. A minimum 6.4 mm diameter bead of silicone shall be applied to the pipe/wallboard interface at the point contact location on both sides of the wall.

A/D FIRE PROTECTION SYSTEMS INC.