

**ULC SYSTEM No. SP989
(For Vertical Separations)**

**F and FH Ratings 1 h
FT and FTH Ratings 0 h**

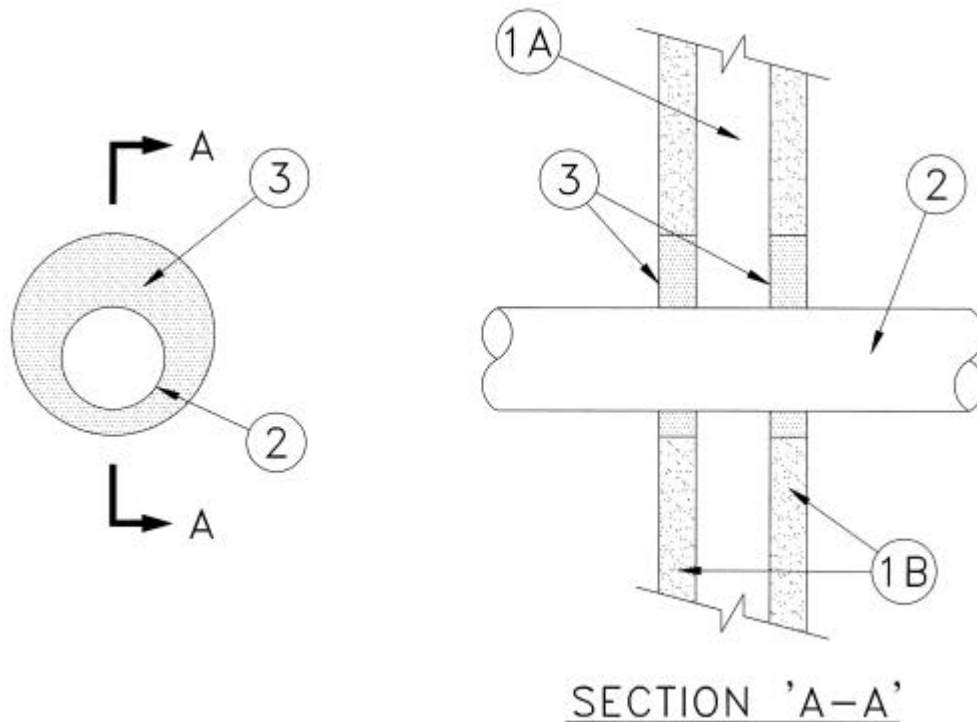

1. Wall Assembly – The 1 h fire-rated gypsum wallboard/stud wall assembly shall be constructed of the materials and in the manner specified in the individual Wall or Partition designs in the Underwriters' Laboratories of Canada List of Equipment and Materials and shall include the following construction features:

(a) Studs – Wall framing may consist of either wood studs or steel channel studs. Wood studs to consist of nominal 50 mm by 102 mm lumber spaced 405 mm OC. Steel studs to be minimum 92 mm wide and spaced maximum 600 mm OC.

(b) Wallboard, Gypsum – One layer, nominal 16 mm thick, 1220 mm wide with square or tapered edges. The gypsum wallboard type, fastener type and sheet orientation shall be as specified in the individual wall or partition design. Maximum diameter of opening in wallboard layers is 19 mm larger than outside diameter of pipe.

2. Metal Pipe or Conduits – One pipe to be installed either concentrically or eccentrically with the firestop system. The annular shall be minimum 6.4 mm to maximum 12.7 mm. The following types and sizes of pipes, conduits or tubing may be used:

(a) Steel Pipe – Nominal 610 mm diameter (or smaller) Schedule 10 (or heavier) steel pipe

(b) Iron Pipe – Nominal 610 mm diameter (or smaller) cast or ductile iron pipe.

(c) Conduit – Nominal 152 mm diameter (or smaller) steel electrical metallic tubing or steel conduit.

(d) Copper Pipe or Tubing – Nominal 152 mm diameter (or smaller) Type L (or heavier) copper tubing.

3. Firestop System Components – (Guide No. 40 U19.13). Type "A/D Firebarrier Intumescent Caulk" installed to fill the annular space throughout thickness of gypsum wallboard layer flush with each surface of the wall.

A/D FIRE PROTECTION SYSTEMS INC.