

ULC SYSTEM No. HW42

(For Vertical or Horizontal Separations)

F and FH Ratings - 1 h
FT and FTH Ratings - 3/4 h

Joint Width – 25 mm Maximum
Movement Capabilities – 18.75% Compression and Extension

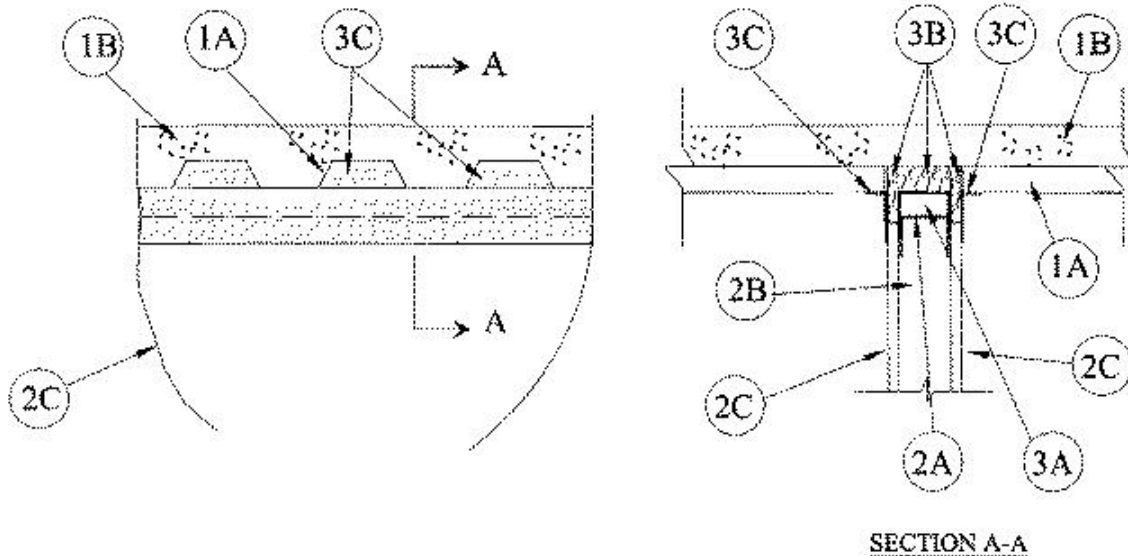

1. Floor Assembly – The fire-rated fluted steel deck/concrete floor assembly shall be constructed of the materials and in the manner described in the individual floor-ceiling design in the ULC List of Equipment and Materials, and shall include the following construction features:

(a) **Steel Floor and Form Units** – Maximum 76 mm deep galvanized steel fluted units.

(b) **Concrete** – Minimum 64 mm thick reinforced concrete as measured from the top plane of the floor units.

1A. Roof Assembly (not shown) - As an alternate to the floor assembly, a fire-rated fluted steel deck roof assembly may be used. The roof assembly shall be constructed of the materials and in the manner described in the individual R900 Roof and Ceiling Assemblies in the ULC List of Equipment and Materials, Fire Resistance. The roof assembly shall include the following construction features:

(a) **Steel Roof Deck** – Maximum 76 mm deep galvanized steel fluted roof deck.

(b) **Roof Insulation** – Minimum 63 mm thick poured insulating concrete, as measured from the top plane of the roof deck.

The hourly rating of the floor or roof assembly shall be equal to or greater than the hourly rating of the wall assembly.

2. Wall Assembly – The 1 h fire-rated gypsum board/steel stud wall assembly shall be constructed of the materials and in the manner described in the individual wall or partition design in the ULC List of Equipment and Materials, and shall include the following construction features:

- (a) **Steel Floor and Ceiling Runners** – Floor and ceiling runners of wall assembly shall consist of galvanized steel channels sized to accommodate steel studs (Item 2b). Ceiling runner to be provided with 52 mm flanges and installed perpendicular to direction of fluted steel floor units. Ceiling runner may be installed within the optional U-shaped deflection channel (Item 3a) with 25 mm gap maintained between the top of the ceiling runner and top deflection channel.
- (b) **Studs** – Steel studs to be minimum 89 mm wide. Studs cut 12 to 19 mm less in length than assembly height with bottom nesting in and resting on floor runner and with top nesting in ceiling runner without attachment. Stud spacing not to exceed 610 mm OC.
- (c) **Gypsum Board** – Gypsum board sheets installed to be a minimum total thickness of 16 mm on each side of wall. Wall to be constructed as specified in the individual Wall or Partition Design in the ULC List of Equipment and Materials, except that a nominal 25 mm gap shall be maintained between the top of the gypsum board and the bottom of the steel floor units, and the top row of screws shall be installed into the studs 89 mm below the valleys of the steel floor units.

3. Joint System – Maximum separation between bottom of floor and top of wall is 25 mm. The joint system is designed to accommodate a maximum 18.75% compression or extension from its installed width. The joint system consists of an optional deflection channel, forming material and a firestop material as follows:

- (a) **Deflection Channel** – (Optional). A nominal 96 mm wide by 78 mm deep minimum 0.6 thick steel U-shaped channel. Deflection channel installed perpendicular to direction of fluted steel floor units and secured to valleys of steel floor units (Item 1a) with steel fasteners or by welds spaced maximum 610 OC. The ceiling runner (Item 2a) is installed within the deflection channel to maintain a 25 mm gap between the top of the ceiling runner and the top of the deflection channel. The ceiling runner is not fastened to the deflection channel.
- (b) **Firestop System Component** – (Guide No. 40 U19.13). Minimum 124 mm thickness of minimum 64 kg/m³ density ULC labelled mineral wool batt insulation cut to the shape of the fluted deck, approximately 33% larger than the area of the flutes, and compressed into the flutes of the steel floor units between the top of the deflection channel and the steel deck. Additional pieces of minimum 64 kg/m³ density mineral wool batt are to be cut to 16 mm wide sections and compressed 33% in thickness and installed edge first to fill the 25 mm gap between the top of the gypsum board and the bottom of the steel floor units. The mineral wool insulation shall be installed flush with each side of the wall.
A/D FIRE PROTECTION SYSTEMS INC.
- (c) **Firestop System Component** – (Guide No. 40 U19.13). Minimum 3.2 mm wet thickness of A/D FIREBARRIER Seal N/S sprayed or brushed on each side of the wall, in the flutes of the steel floor units, and between the top of the wall and the bottom of the steel floor units to completely cover mineral wool and overlap a minimum of 13 mm onto gypsum board and steel deck on both sides of wall.
A/D FIRE PROTECTION SYSTEMS INC.