

ULC System No. SP1093

(For Vertical Separations)

F and FH Ratings — 1 and 2 h (See item 1)
FT and FTH Ratings — ½ and 1 h (See item 1)

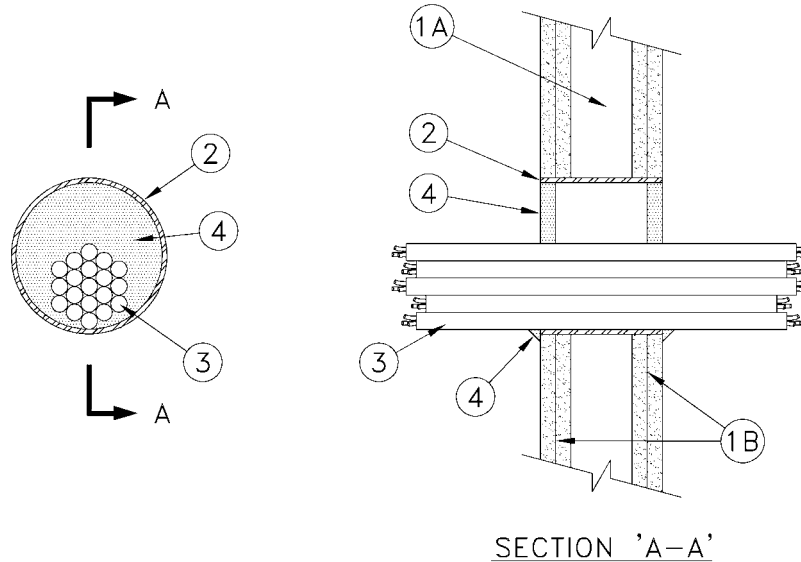

1. Wall Assembly – The 1 or 2 h fire-rated gypsum board/stud wall assembly shall be constructed of the materials and in the manner specified in the individual Wall and Partition Designs in the ULC Fire Resistance Directory and shall include the following construction features:

A. Studs – Wall framing may consist of either wood studs or steel channel studs. Wood studs to consist of nominal 38 by 89 mm lumber spaced 406 mm OC. Steel studs to be minimum 92 mm wide and spaced maximum 610 mm OC

B. Gypsum Board – 16 mm thick, 1220 mm wide with square or tapered edges. The gypsum board type, thickness, number of layers, fastener type and sheet orientation shall be as specified in the individual Wall or Partition design. Maximum diameter of opening is 140 mm.

The hourly F and FH ratings of the firestop system are equal to the hourly fire rating of the wall assembly in which it is installed.

The hourly FT and FTH ratings of the firestop system are equal to ½ h and 1 h for 1 h and 2 h rated walls respectively.

2. Steel Sleeve — Cylindrical sleeve fabricated from 0.46 mm thick galvanized sheet steel and having a minimum 25 mm lap along the longitudinal seam. Sleeve installed flush with both surfaces of wall. Sleeve installed by coiling the sheet steel to a diameter

smaller than the through opening, inserting the coil through the openings and releasing the coil to let it uncoil against the circular cutouts in the gypsum board layers.

3. Cables — Maximum 89 mm diameter tight bundle of cables to be installed either concentrically or eccentrically within the opening. Aggregate cross-sectional area of cables in opening to be a maximum 43 % of the cross-sectional area of the opening. The annular space between the cable bundle and the periphery of opening shall be minimum 0 mm (point contact) to maximum 51 mm.. Any combination of the following types and sizes of cables may be used:

- A. Maximum 200 pair No. 22 AWG (or smaller) copper conductor cable with polyvinyl chloride (PVC) jacketing and insulation.
- B. Maximum 3/C No. 2/0 AWG (or smaller) aluminum or copper conductor service entrance cable with XLPE or PVC insulation and jacket.
- C. Maximum 3/C No. 8 AWG (or smaller) nonmetallic sheathed cable with copper conductors, PVC insulation and jacket.
- D. Maximum 7/C No. 12 AWG (or smaller) multiconductor power and control cables with XLPE or PVC insulation and XLPE or PVC jacket.
- E. Maximum RG/U (or smaller) coaxial cable with fluorinated ethylene insulation and jacketing.
- F. Maximum 110/125 fiber optic cable with PVC insulation and jacketing.
- G. Maximum 4 pair No. 24 AWG (or smaller) copper conductor data cable with Hylar jacket and insulation..
- H. Maximum 4/C No. 2/0 aluminum or copper conductor aluminum or steel clad TECK 90 cable with PVC jacketing..
- I. Maximum 1/C No. 350 kcmil (or smaller) copper conductor cable with XLPE or PVC jacket.

• **4. Firestop System Component** (Guide No. 40 U19.13) XHJZC — Minimum 16 mm thickness of A/D FIREBARRIER Intumescent Caulk applied within the annulus, flush with each surface of wall. The sealant is also applied to fill all the interstices between the cables, prior to securing the bundle together, at both surfaces of wall. Additional caulk to be applied such that a minimum 6.4 mm diameter bead is formed, at the point of contact of cable bundle and wall, on both surfaces of wall.