

SYSTEM No. SP384
(For Horizontal or Vertical Separations)

F Rating – 1-1/2 h
FT, FH and FTH Ratings – 0 h

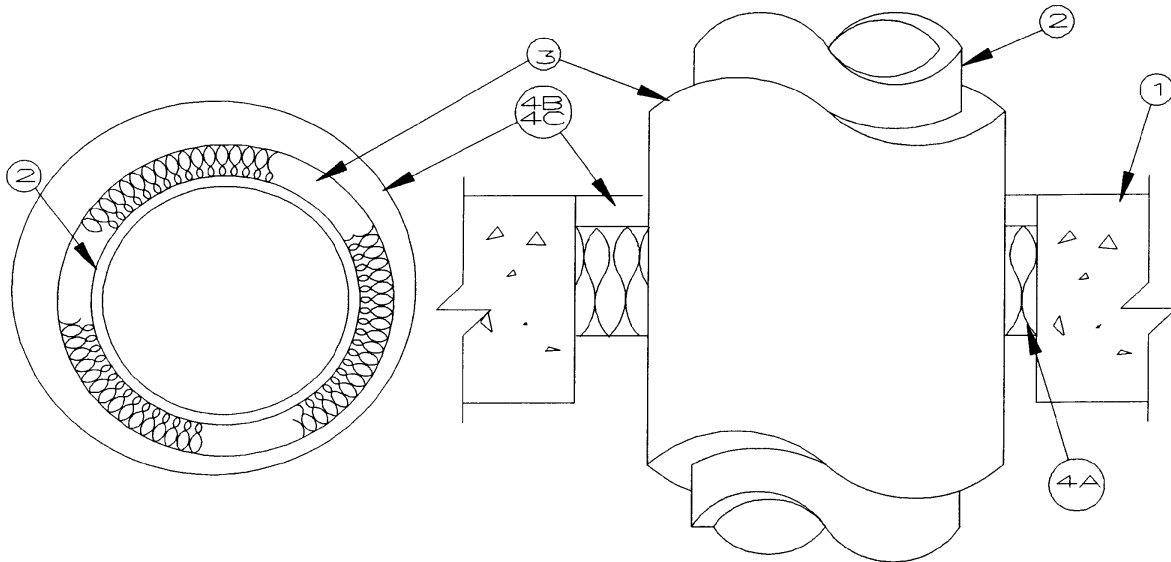

1. Floor or Wall – Minimum depth or thickness as necessary for required grade of fire separation but not less than 115 mm. Normal-density ($2400 \pm 50 \text{ kg/m}^3$) concrete. Maximum size of opening 254 mm diameter.

2. Pipe – Nominal 156 mm OD (or smaller), 3.8 mm thick (or heavier) copper pipe, reliably supported above through-opening. Pipe to be wrapped with Pipe Insulation (Item 3). Annular opening shall be 0 mm (point contact) to maximum 80 mm.

3. Pipe Insulation – Pipe to be wrapped with 13-19 mm thick ULC labelled mineral wool or fibreglass pipe insulation with minimum 56 kg/m^3 density jacketed on the outside with an all service jacket. Longitudinal joints sealed with factory-applied self-sealing lap tape. Transverse joints sealed with butt tape supplied with the product.

• **4. Firestop System Components** – (Guide No. 40 U19.13).

- (a) Type "A/D FIREBARRIER Mineral Wool" insulation to be compressed 33% (minimum) within opening to a minimum depth of 100 mm and recessed 6.4 mm from top surface of slab.
- (b) Type "A/D FIREBARRIER Silicone Sealant" caulk grade applied over insulation to a depth of 6.4 mm minimum flush with top surface of slab. Additional material applied to form a nominal 6.4 mm crown around the pipe where the annular space is less than 6.4 mm. For vertical separations, material shall be applied symmetrically on both sides of wall.

OR

- (c) For horizontal separations only, Type "A/D FIREBARRIER Silicone Sealant SL" applied over insulation to a depth of 6.4 mm minimum flush with top surface of slab. Additional caulk grade material (Item 4b) applied to form a nominal 6.4 mm crown around the pipe where the annular space is less than 6.4 mm.

A/D FIRE PROTECTION SYSTEM INC.