

SYSTEM No. SP956
(For Horizontal or Vertical Separations)

F and FH Ratings – 3 h
FT and FTH Ratings – 0 h

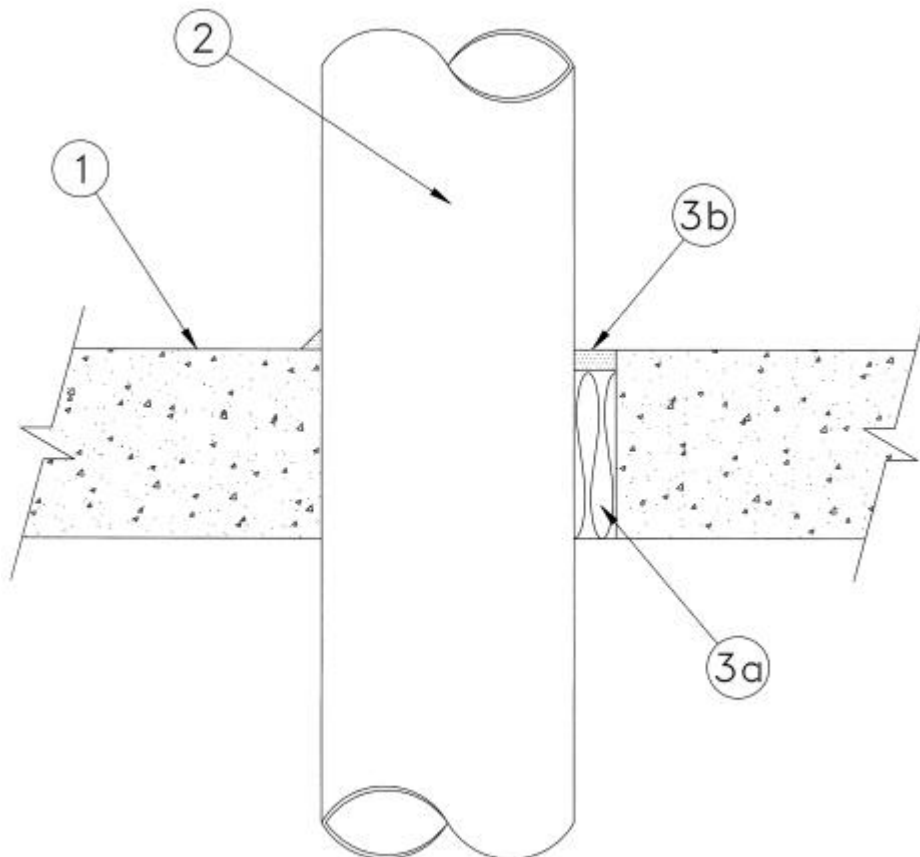

1. Floor or Wall Assembly– Minimum 115 mm thick reinforced normal-density (2400 kg/m³) concrete. Wall may also be constructed of nominal 200 mm thick concrete block. Maximum diameter of opening is 178 mm.

2. Pipes or Conduits – One metallic pipe, conduit or tubing to be installed within the firestop system. Pipe, conduit or tubing to be rigidly supported on both sides of floor or wall assembly. The annular space shall be 0 mm (point contact) to maximum 25 mm. The following types and sizes of pipes, conduits or tubing may be used:

(a) Steel Pipe – Nominal 610 mm diameter (or smaller) Schedule 10 (or heavier) steel pipe.

(b) Iron Pipe – Nominal 610 mm diameter (or smaller) cast or ductile iron pipe.

(c) Conduit – Nominal 152 mm diameter (or smaller) steel electrical metallic tubing or steel conduit.

(d) Copper Pipe or Tubing – Nominal 152 mm diameter (or smaller) Type L (or heavier) copper tubing.

SP956 continued...

- **3. Firestop System Components** – (Guide No. 40 U19.13).

(a) Batts and Blankets – Type "A/D FIREBARRIER Mineral Wool" compressed 33% and installed within the opening to a minimum depth of 100 mm and recessed 13 mm from top surface of slab or both sides of wall.

(b) Sealants – Type "A/D FIREBARRIER Intumescent Caulk", applied to the top of mineral wool insulation to a minimum depth of 13 mm. Additional material installed to form a crown of minimum 13 mm at point contact where the pipe contacts the edge of opening. For vertical installations, sealant to be applied symmetrically on both sides of wall.

A/D FIRE PROTECTION SYSTEMS INC.